

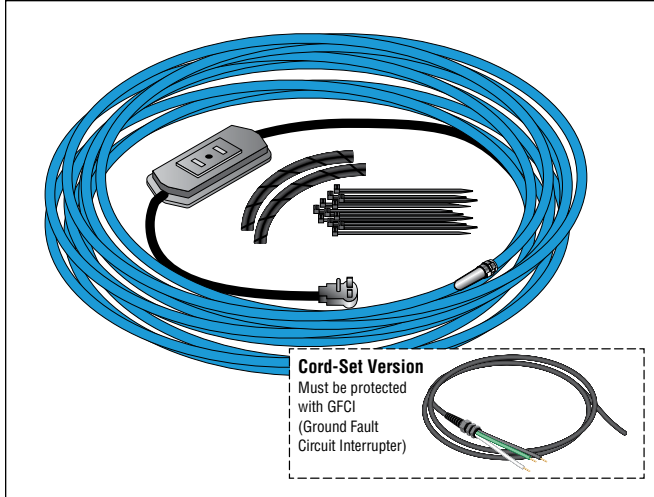

Paladin®

Pre-Assembled Heating Cable Sets for Pipe Freeze Protection

Installation Instructions



Cord-Set Version
Must be protected with GFCI (Ground Fault Circuit Interrupter)

Paladin Kit Contents

- Paladin heating cable (GFC shown)
- *Optional Cord-Set (CS) power connection
- Cable ties
- Cable Guards (x2)
- Installation Instructions

Table of Contents

General Information	1
External Small Diameter Installation	3
External Large Diameter Installation	5
Other Installation Examples	7
Thermostat Sensor Location and Insulation Installation	10
Electrical System Check	11
Seasonal Inspection by User	11
Limited Warranty	12
Extended Warranty Application Form	13

General Information

Paladin systems can be used on all metal and non-metal pipe materials including but not limited to copper, polyethylene and ABS/PVC. Paladin systems are commonly used in applications such as fresh water supply pipes, effluent and sewage pipes, drain pipes and culverts, forced mains, tank heating, soil heating and more. Paladin employs the performance and operating characteristics of self-regulating heating cable technology and can be used with thermal insulation to increase energy efficiency. Paladin is applied on the outside (externally) of the pipe to provide reliable freeze protection. Paladin is generally applied in a single run on the bottom side of a pipe (depending on application) due to the high performance capability of the conductive polymer technology. Paladin systems can provide efficient reliable freeze-protection for most exposed pipe systems such as those found in cold storage buildings and barns or under cabins and cottages.

1. Paladin is suitable for use on metal and non-metal pipes.
2. As these systems are wet location approved they can be installed in fresh water drainage tiles and around tanks. Also suitable for direct earth burial.
3. Exposure to temperatures above 150°F (65°C) while operating will shorten the expected life of the heating cable. Maximum exposure temperature is 185°F (85°C) when not powered. Before installing on hot water pipes, set the water heater thermostats below 150°F (65°C).
* Do not install in temperatures below -40°F (-40°C).
4. Remove any old heating tapes or insulation before installing the Paladin heating cable.
5. Use a minimum of 1/2" thick insulation or equivalent.
6. The minimum bending radius of the heating cable is 1/2".
7. If the Paladin system must be taken off and re-installed carefully follow all installation instructions.
8. Leave these instructions with the user for future reference.
9. These systems can be used with thermostats or timers where applicable to improve energy efficiency.

Paladin is a technically advanced product. Handle it with proper care and be sure not to damage the outer sheaths or jackets of the cable.

Read the Warnings and Installation Instructions completely before installing this product.

Approvals



WARNING:

Important Safety Instructions and Rules for Safe Installation and Operation

- A. Read these rules and instructions carefully. Failure to follow them could result in serious bodily injury and/or property damage.
- B. Check your local building, plumbing and electrical codes before installing. You must comply with their rules.
- C. Before installing this product have the electrical outlet checked by an electrician to make sure it has been installed in accordance with the National Electrical Code and Canadian Electrical Code. Be certain all electrical connections are protected from rain and other water (dry location). The heating cable must be ground fault protected (included in GFC models, required on site for CS models).
- D. Before installing or servicing your Paladin system BE CERTAIN that the power source is disconnected.
- E. Do not use extension cords.
- F. Never tamper with or alter the electrical apparatus associated with your Paladin system.
- G. Check unoccupied residences regularly to ensure that all systems are operating properly.
- H. The cable jacket must not be cut, nicked, or worn down, therefore:
 - Never cut the cable's outer jacket.
 - Do not install the cable where objects might hit it or cut it or where it might be damaged by rubbing against rough surfaces.
 - Before installation, file and remove any sharp edges on the installation surface which might damage the cable. Make sure the cables cross only smooth, non-abrasive surfaces.
 - Protect the complete system with a protective metal sheath where it might be damaged by animals or impact.
 - Do not use any wire or clamps to attach the cable to the pipe. Use 1/2" or 1" tape, fiberglass tape, or plastic ties.
- I. Do not use nails, metal clamps, wires or other devices that might cut the cable or cord to support it between the pipe and receptacle.
- J. If you discover a nick or worn spot on your cable, immediately disconnect the system and replace the cable. Inspect the cable periodically for damage. And remember to replace any damaged insulation after each inspection of the cable.
- K. Never attempt to splice or repair a damaged cable. Replace it with a new unit. The system is not designed to be repaired and to do so may create a danger of fire or shock.
- L. Do not install the cable close to flammable materials, liquids, or fumes. If the cable is cut while the system is energized and if there is moisture present, there is a risk of fire and flammable objects or fumes near the cable might be ignited.

WHEN PERFORMING WORK OR REPAIRS ON YOUR WATER SYSTEM BE SURE TO UNPLUG YOUR Paladin SYSTEM FROM THE POWER SUPPLY.

Pre-Installation Information

General Requirements For Pipe Freeze Protection

Install with a minimum of 1/2" fire-resistant, waterproof thermal insulation.

General Instructions

- Install only in accessible locations; do not install behind walls or where the cable would be hidden.
- Do not run the heating cable through walls, ceilings, or floors.
- Connect only to properly grounded outlets that have been installed in accordance with all prevailing national and local codes and standards and are protected from rain and other water.

Important: For the Heat-Line warranty to be valid, you must comply with all the requirements outlined in these guidelines.

All thermal and design information provided here is based upon a "standard" installation with heating cable fastened to an insulated pipe. For any other application or method of installation, consult Heat-Line at (800) 584-4994.

Bending the Cable

When positioning the heating cable on the pipe, do not bend tighter than 1/2" radius.

The heating cable does not bend well on a flat plane. Do not force such a bend as heating cable may be damaged.

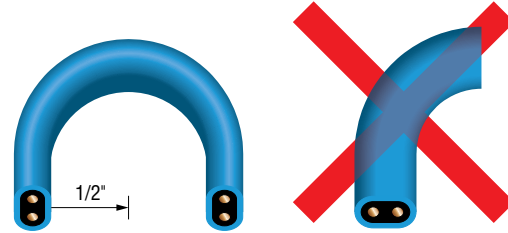

Paladin Nominal Power Output Rating on Metal Pipes at 120 V/240 V

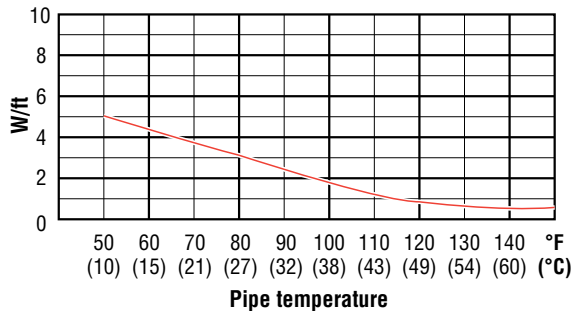

Optional Accessories

HLA-120	NEMA 1 General Purpose 120V only plug-in thermostat
HLPC-TIMER	General Purpose 120/240V 20 Amps Percentage cycle timer
GF-STAT	NEMA 4X Ground Fault Protected Thermostat 120V /240V 30amp
MA-10	GFCI/ELCI Electrical Equipment Protection Device
TAPE-FOIL	Professional Grade All Weather Foil Tape 2.83" x 150' (72mm x 46m)
INSUL-1.00	Closed cell polyethylene insulation sleeve for 1" ID pipe (6' long, 1 5/8" ID, 3/4" thick wall)
INSUL-1.25	Closed cell polyethylene insulation sleeve for 1 1/4" ID pipe (6' long, 1 7/8" ID, 3/4" thick wall)
INSUL-2.00	Closed cell polyethylene insulation sleeve for 2" ID pipe (6' long, 2 5/8" ID, 3/4" thick wall)
INSUL-3.00	Closed cell polyethylene insulation sleeve for 3" ID pipe (6' long, 3 1/2" ID, 3/4" thick wall)
INSUL-4.00	Closed cell polyethylene insulation sleeve for 4" ID pipe (6' long, 4 1/2" ID, 1" thick wall)
INSUL-FOIL	Aluminum Reflective Metalized Foil Bubble Insulation (16" wide)
INSUL-LABEL	Electric Heat Trace Caution Label for Insulation

Ordering Chart

Paladin Series Product Code	
Example: PLDI - 100 - GFC or CS	
Product	Cord-Set Type
PLDI 120 volt Paladin 5 watt, TPR heater jacket	GFC Ground fault protected
PLDI2 240 volt Paladin 5 watt, TPR heater jacket	CS Cord connected (No GFCI)
	Length of Heater
	10 to 120 feet 120 volt systems
	10 to 240 feet 240 volt systems

External Small Diameter Installation

1 External Small Diameter

Determine the length of cable required

- For systems with pipe diameters up to 2" I.D. a single straight run is often sufficient.*
- For systems with pipe diameters greater than 2" see External Large Diameter Installation on page 4.

Note: Inspect piping for burrs, rough surfaces, or sharp edges. Remove if necessary. Cable guards are available as an additional accessory for cable protection if required.

* Assuming the lowest outside temperature is 0°F (-18°C), with a minimum of 1/2" thick waterproof, fire-resistant thermal insulation (preformed foam). For protection to -20°F (-29°C), use 1" thick insulation.

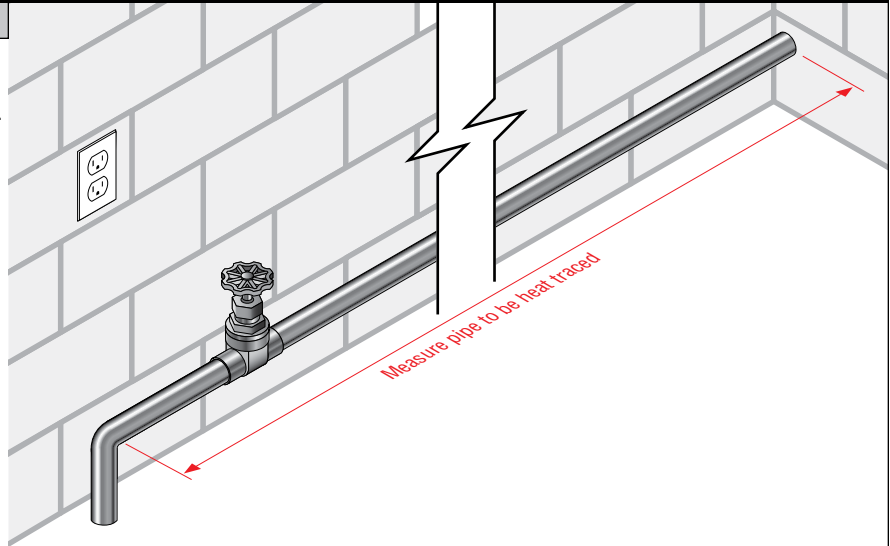

2 External Small Diameter

- To provide extra heat at valves and other fitting areas, simply wrap extra heating cable at these areas.

Pipe diameter (IPS) inches	Heating cable	
	feet	(meters)
1/4	0.3	(0.09)
1/2	0.8	(0.24)
3/4	1.3	(0.4)
1	2.0	(0.6)
1-1/4	3.3	(1.1)
1-1/2	4.3	(1.3)
2	4.3	(1.3)

Note: It is safe for the heating cable to overlap.

- To protect heater over rough or sharp edges Cable Guards can be installed.

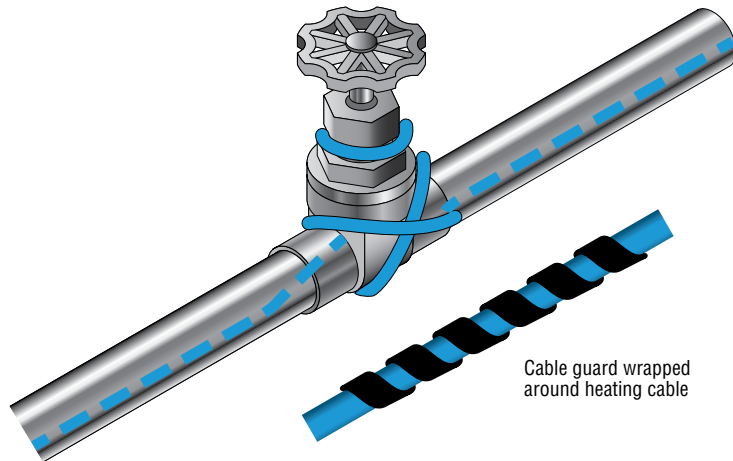

Cable guard wrapped around heating cable

3 External Small Diameter

- Carefully remove your Paladin system. It comes complete with all parts as required pre-assembled.

- It is recommended that a single circuit (15 amp) be installed by a qualified person for dedicated use of the Paladin system. **Do not use extension cords.**

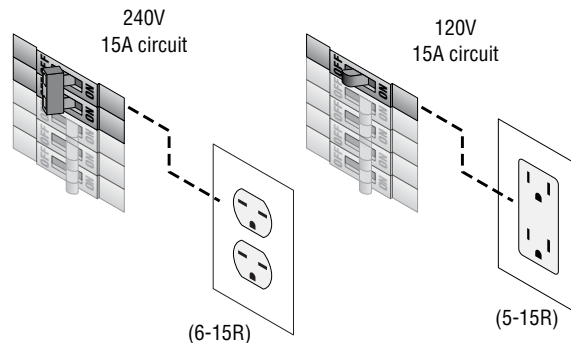
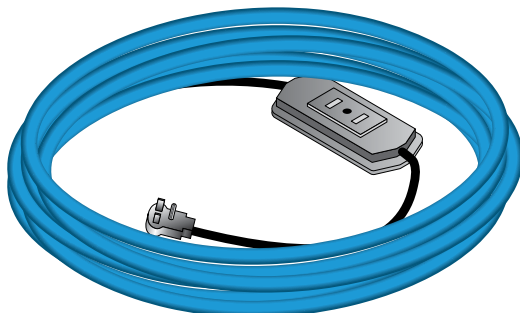

4 External Small Diameter

Apply cable to the pipe

- Ensure that the heating cable voltage rating is suitable for the service voltage available.
- If your Paladin cable set is the same length as the pipe, run it straight along the pipe in the 4, 6 or 8 o'clock position.

When laying out the heating cable, AVOID:

- Sharp edges
- Excessive pulling force or jerking
- Kinking and crushing
- Walking on it, or running over it with equipment

Option: Apply Aluminum Foil Tape to outside diameter of pipe prior to installing heating cable to increase conductive heat transfer.

Single Straight Line Method

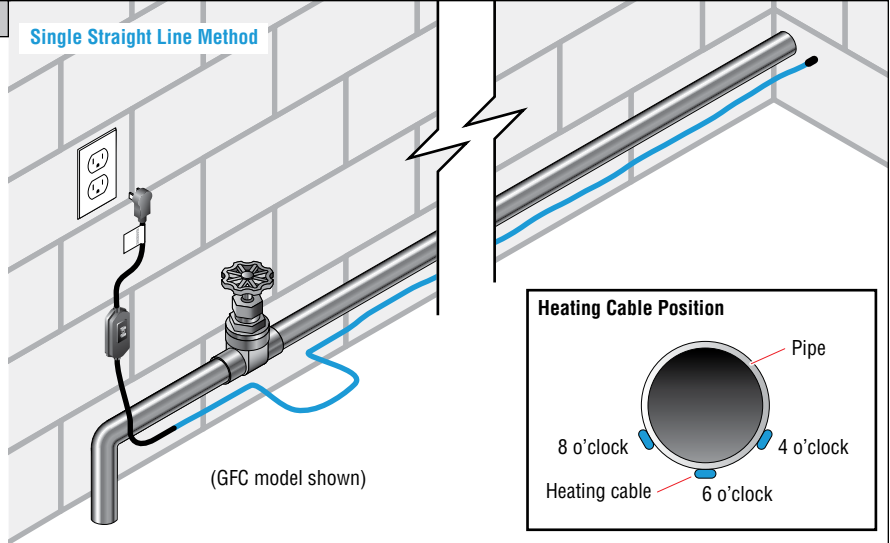

5 External Small Diameter

- Fasten the cable at one foot intervals using aluminum foil tape*, quality fiberglass tape or plastic cable ties.

* Aluminum foil tape may be installed over entire length of heating cable for increased heat transfer and to keep heating cable in constant contact with pipe wall.

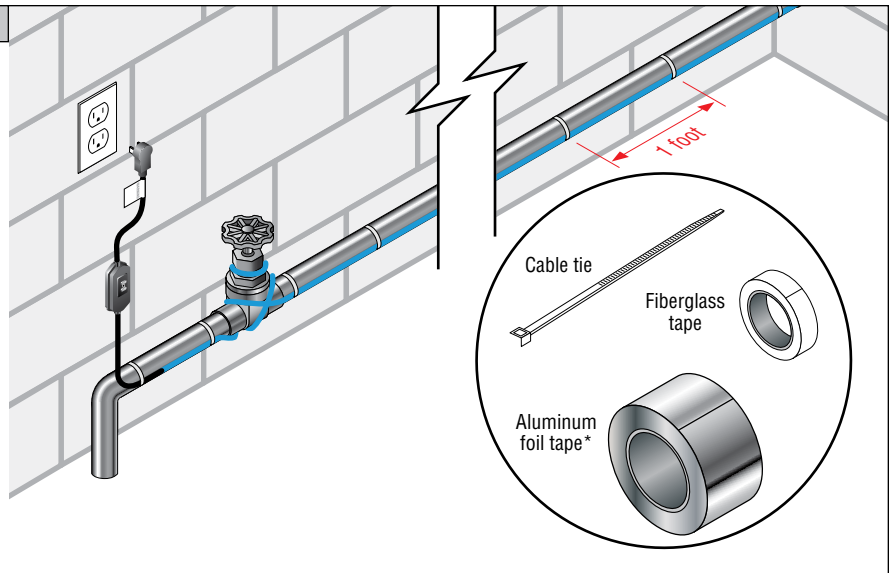

6 External Small Diameter

- If the Paladin cable is longer than the pipe, loop the excess heater back up along the pipe. It is safe for the heating cable to overlap.

Note: Never cut the heating cable to shorten.

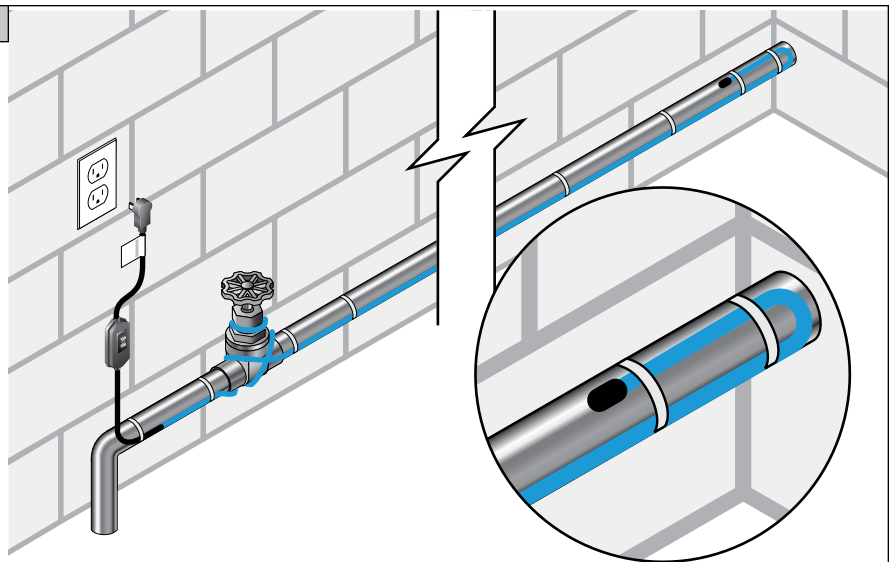

7 External Small Diameter

Protect the system with insulation

Insulation may include foil bubble insulations, fiberglass pipe insulations in dry locations or foam sleeve insulations outside in wet locations.

Spray foam is not generally recommended. Consult Heat-Line prior to installing spray foam insulation.

- Before insulating ensure that there is no cable damage, such as nicks or cuts.

Note: Pipes must be insulated for maximum efficiency and performance.

- Apply 'Electric Traced' labels on the outside of the insulation at 10 foot (3m) intervals on alternate sides to indicate presence of electric cables.

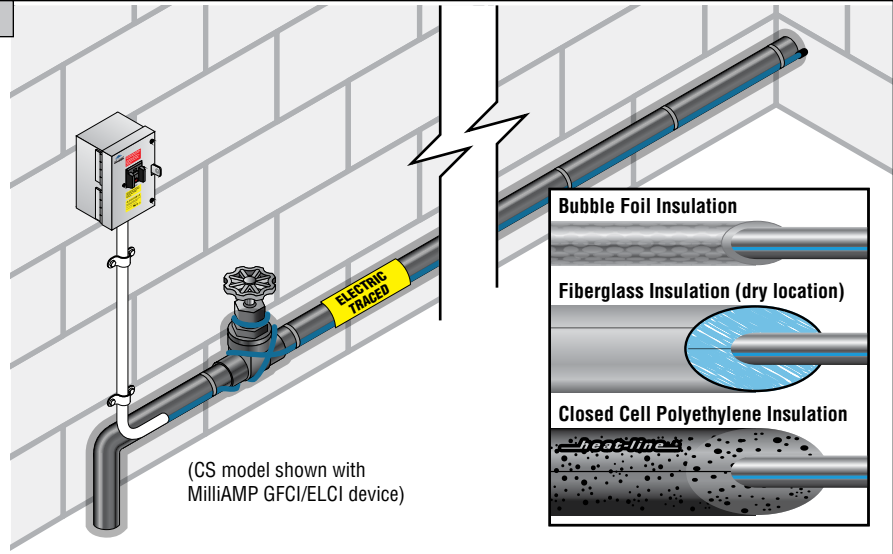

External Large Diameter Installation

1 External Large Diameter

Determine the length of cable required

- For systems with pipe diameters over 2" I.D. a dual trace installation is recommended. For pipes greater than 4" consult Heat-Line to discuss your particular requirement.*

Note: Inspect piping for burrs, rough surfaces, or sharp edges. Remove if necessary. Cable guards are available as an additional accessory for cable protection if required.

* Assuming the lowest outside temperature is 0°F (-18°C), with a minimum of 1/2" thick waterproof, fire-resistant thermal insulation (preformed foam). For protection to -20°F (-29°C), use 1" thick insulation.

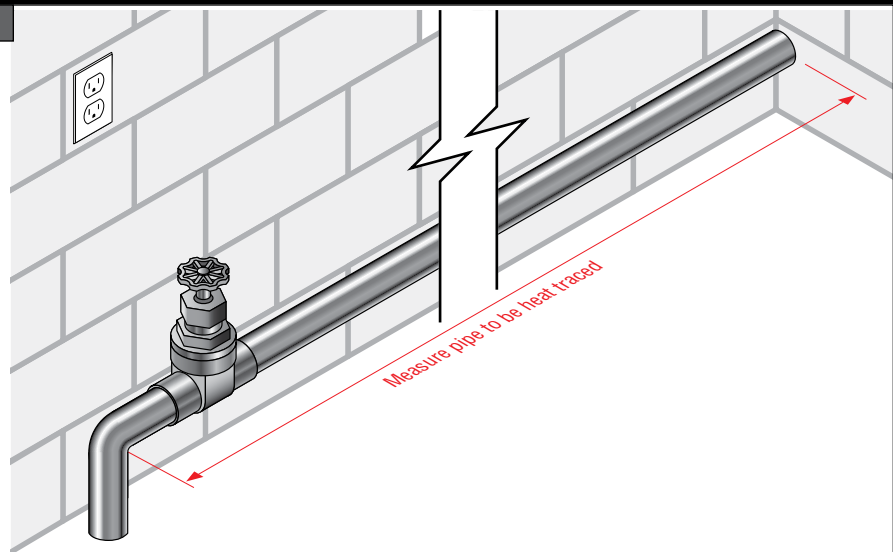

2 External Large Diameter

- To provide extra heat at valves and other fitting areas, simply wrap extra heating cable at these areas.

Pipe diameter (IPS) inches	Heating cable	
	feet	(meters)
2	4.3	(1.3)
3	4.3	(1.3)
4	4.3	(1.3)

Note: It is safe for the heating cable to overlap.

- To protect heater over rough or sharp edges Cable Guards can be installed.

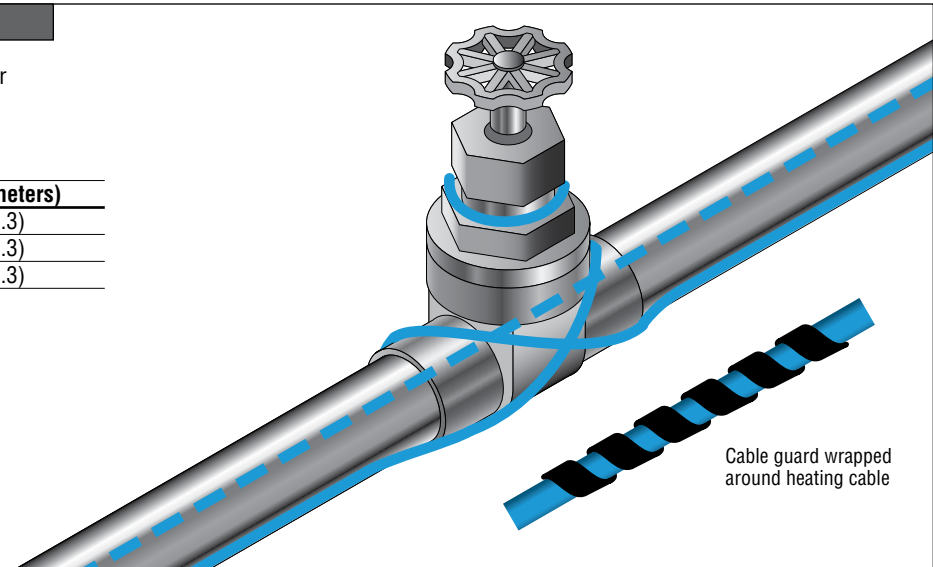

3 External Large Diameter

- Carefully remove your Paladin system. It comes complete with all parts as required pre-assembled.

- It is recommended that a single circuit (15 amp) be installed by a qualified person for dedicated use of the Paladin system. **Do not use extension cords.**

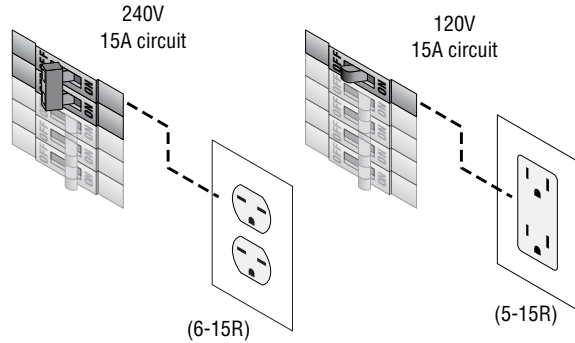
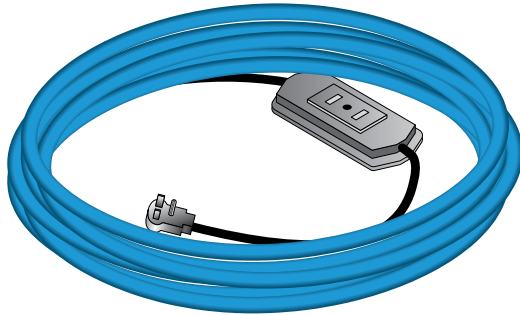

4 External Large Diameter

Apply cable to the pipe

- Ensure that the heating cable voltage rating is suitable for the service voltage available.
- For pipes 2" to 4" I.D. your Paladin cable set should be at least double the length as the pipe. Run the heating cable along the pipe in the 4 and 8 o'clock position.

When laying out the heating cable, AVOID:

- Sharp edges
- Excessive pulling force or jerking
- Kinking and crushing
- Walking on it, or running over it with equipment

Option: Apply Aluminum Foil Tape to outside diameter of pipe prior to installing heating cable to increase conductive heat transfer.

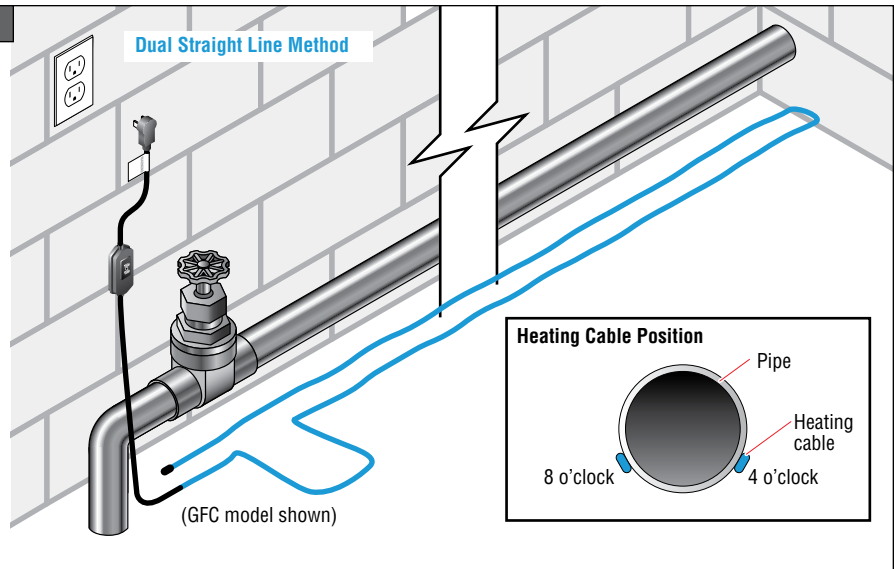

5 External Large Diameter

- Fasten the cable at one foot intervals using aluminum foil tape*, quality fiberglass tape or plastic cable ties.

* Aluminum foil tape may be installed over entire length of heating cable for increased heat transfer and to keep heating cable in constant contact with pipe wall.

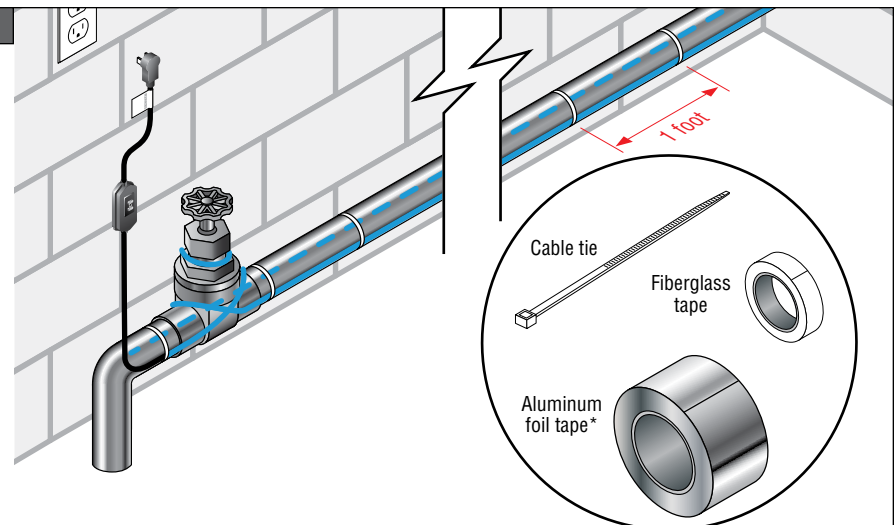

6 External Large Diameter

- If the Paladin cable is longer than the pipe, loop the extra heater back up along the pipe or spiral to use up the excess. It is safe for the heating cable to overlap.

Note: Never cut the heating cable to shorten.

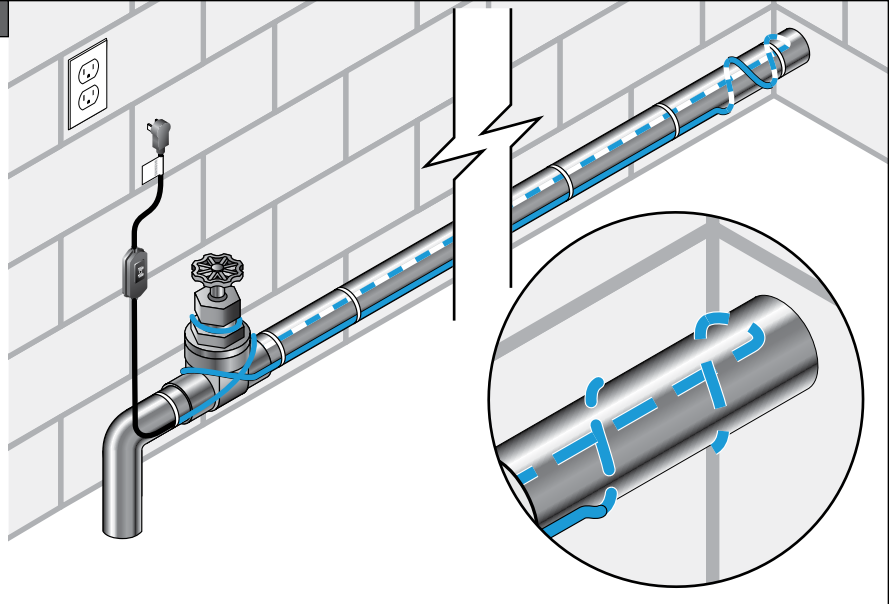

7 External Large Diameter

Protect the system with insulation

Insulation may include foil bubble insulations, fiberglass pipe insulations in dry locations or foam sleeve insulations outside in wet locations. Spray foam is not generally recommended. Consult Heat-Line prior to installing spray foam insulation.

- Before insulating ensure that there is no cable damage, such as nicks or cuts.

Note: Pipes must be insulated for maximum efficiency and performance.

- Apply 'Electric Traced' labels on the outside of the insulation at 10 foot (3m) intervals on alternate sides to indicate presence of electric cables.

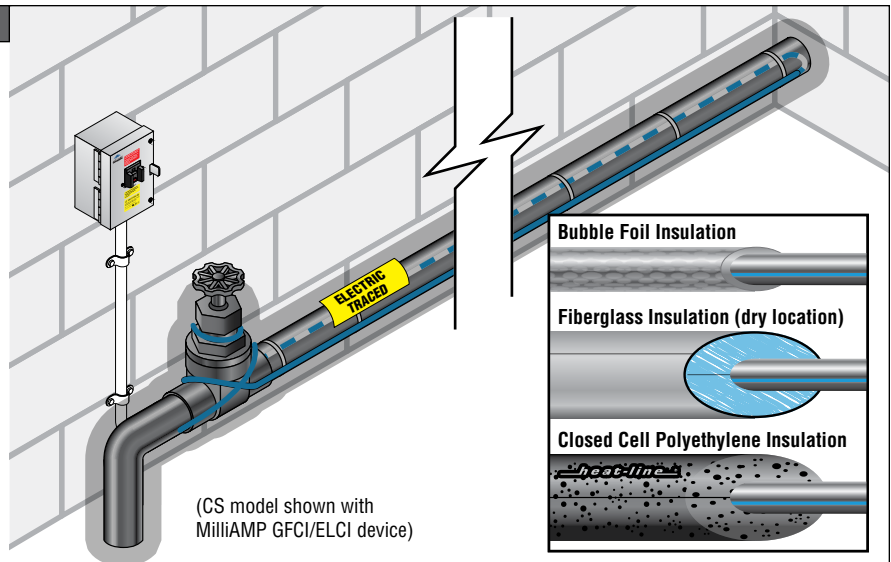

Other Installation Examples

Multiple Pipe Application

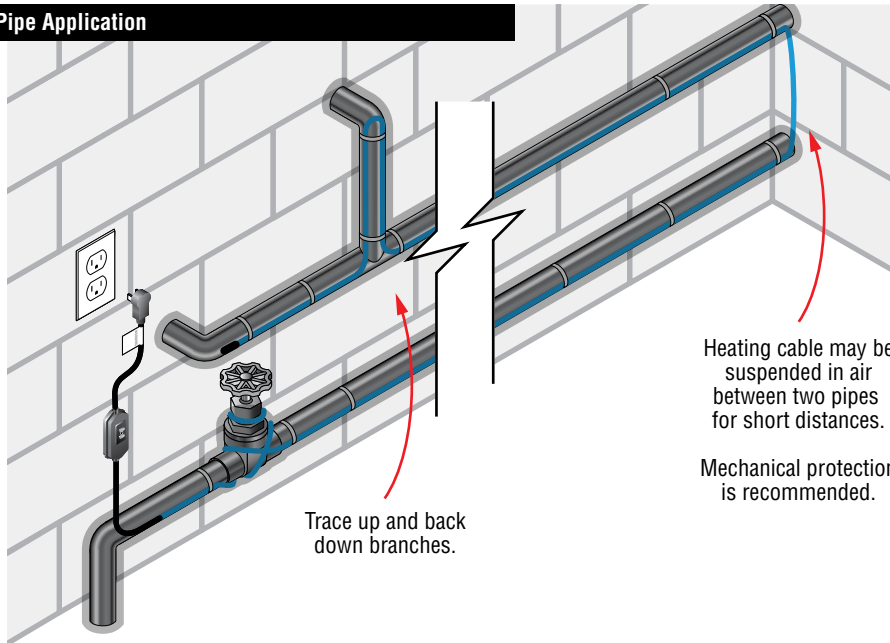

Freeze Protecting a Drain or Culvert

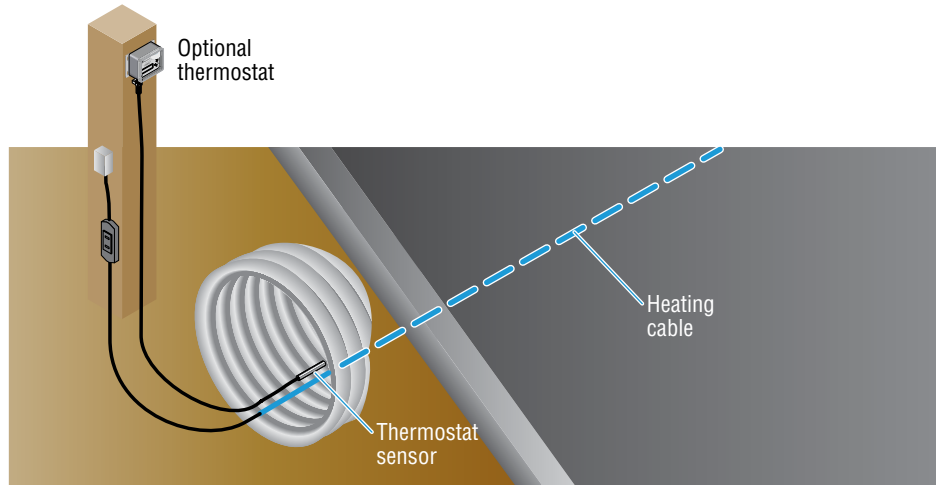

Unheated Structure Applications: Drains and Water Supply

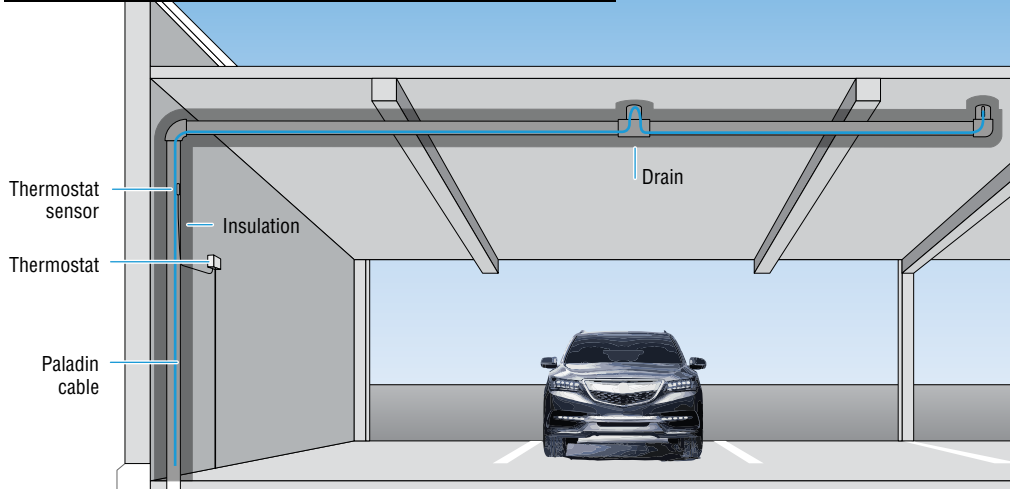

Soil Heating System

Cross section

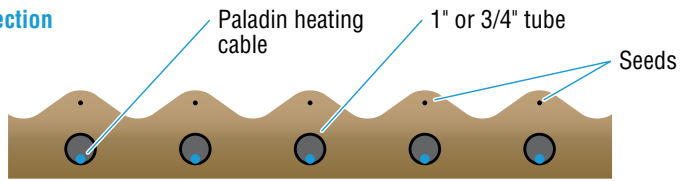

Top view

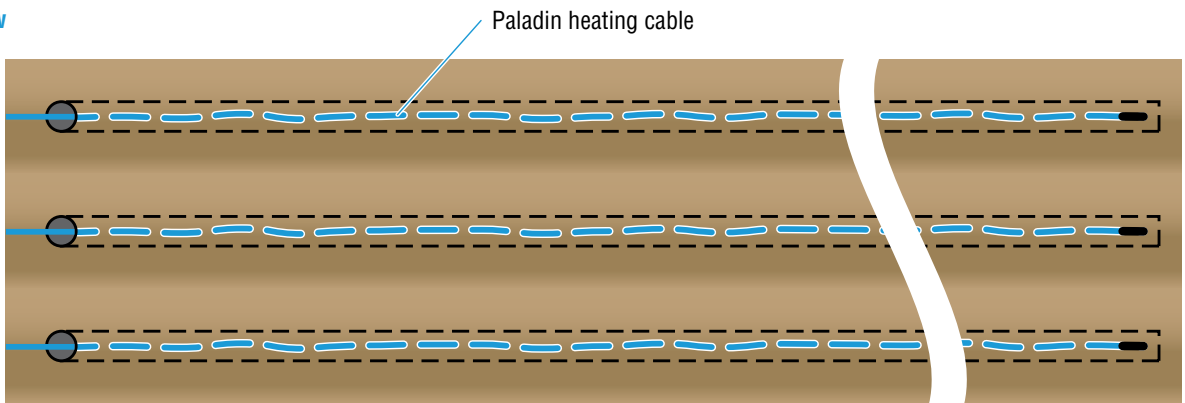

Side view

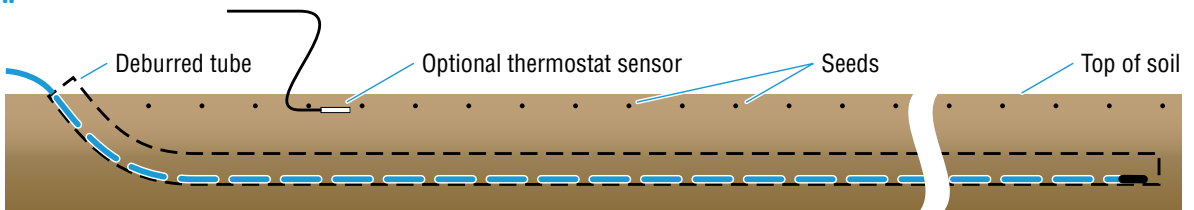

Thermostat Sensor Location and Insulation Installation

Thermostats and timers are not required to operate the Paladin system. A thermostat however can be added to duty cycle the heating cable in an on/off operation saving power consumption and used to maintain a certain pipe temperature.

Insulation is recommended for all new pipe installations, even where the pipe is to be buried. For existing pipe applications, insulation is only required where the pipe is exposed to ambient outdoor temperatures, and/or where the pipe is above the ground. Insulation aids in heat retention making the heating cable more energy efficient and providing cold weather reliability.

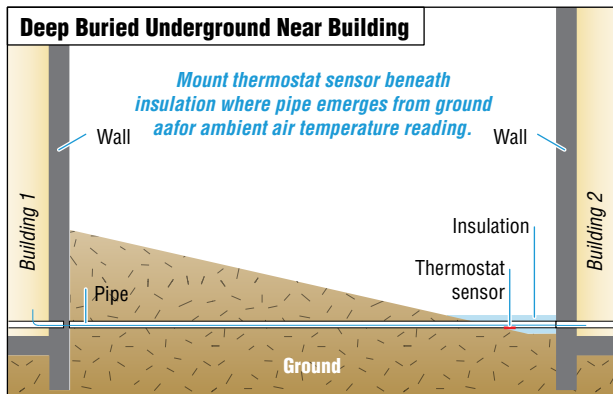
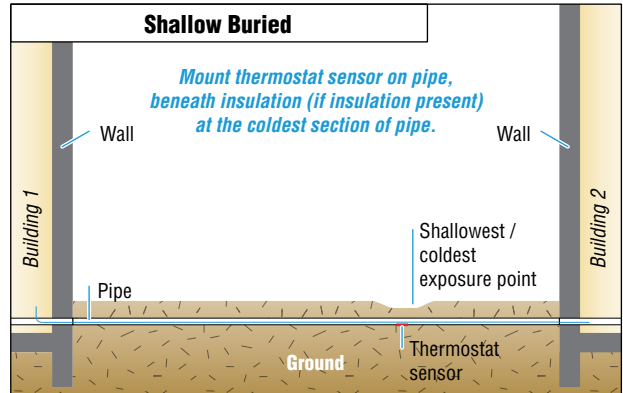
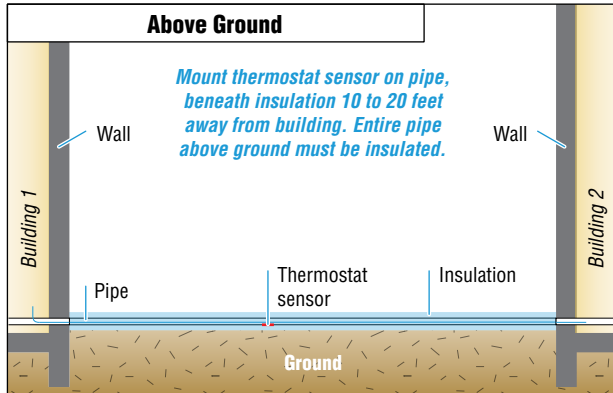
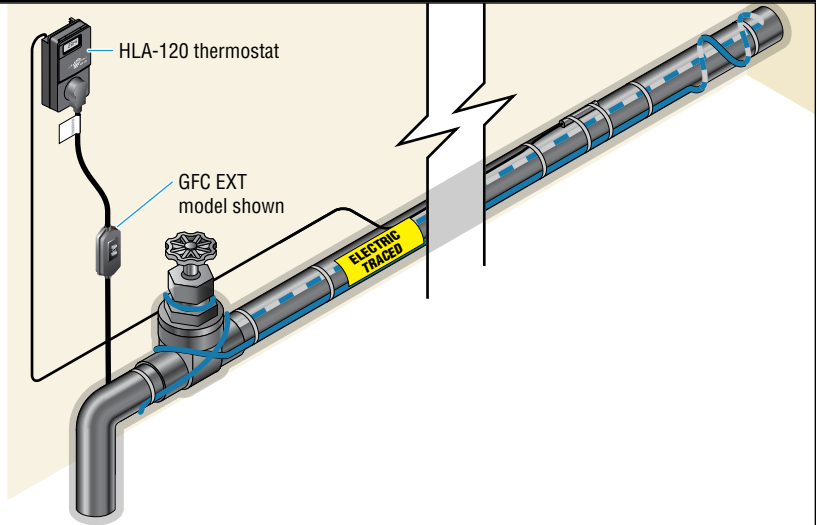

ELECTRICAL SYSTEM CHECK

- Unpack the Paladin system plug from its protective package.
- Plug into your dedicated outlet. 120V 5-15R outlet for 120V systems or 240V 6-15R outlet for 240V systems.
- Push reset button on the cord set ground fault device until light comes ON. If light does not illuminate check power to outlet. Do not remove or tamper with the cord set. If used with a thermostat it may be necessary to bypass the thermostat control and plug directly into receptacle to perform test.
- Push test button and light will go OFF. This indicates that the electrical circuit is intact and fully protected.
- Push reset button again and light will come ON. This indicates that your Heat-Line is working.
- Follow this test procedure before each season and monthly while in use.

Your Heat-Line is now fully functional.

If at any time your Heat-Line system fails to work call your local electrician or Heat-Line for assistance at (800) 584-4944.

Unplug when not in use.

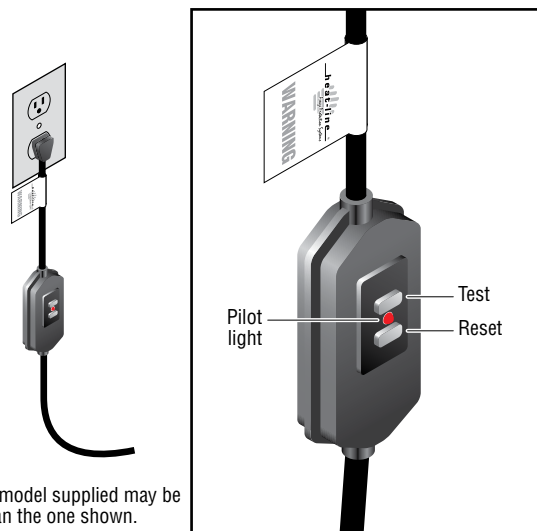

Note: GFCI model supplied may be different than the one shown.

SEASONAL INSPECTION BY USER

IMPORTANT: While the Paladin cable can be left plugged in year round, it will use less energy if you unplug it during non-freezing weather. Each season before you plug it back in, make the following inspection:

- Check the entire system for signs of damage (may be evidenced by damage to insulation).
- Inspect the exposed portion of the cable for evidence of cuts, nicks, abrasions, gnawing by animals, or other physical damage.

- If there is damage, immediately replace the cable. Do not attempt to repair any part of the cable.
- After a thorough inspection, complete the **ELECTRICAL SYSTEM CHECK**.
- Ground fault device should be stored in dry location off of concrete floors or the ground.

Unplug when not in use.

Limited Warranty

During the time periods and subject to the conditions hereinafter set forth, Heat-Line will repair or replace to the original user any portion of your Paladin Series product which proves defective in materials or workmanship of Heat-Line. Contact Heat-Line or your installer for warranty service.

At all times Heat-Line shall have and possess the sole right and option to determine whether to repair or replace defective equipment, parts or components. **Damage due to natural events or conditions beyond the control of Heat-Line are NOT COVERED BY THIS WARRANTY.**

STANDARD WARRANTY PERIOD: 60 months from date of purchase or 63 months from date of manufacture, whichever ever occurs first.

EXTENDED WARRANTY PERIOD: 120 months from date of purchase or 123 months from date of manufacture, whichever ever occurs first.

ACCESSORIES, COMPONENTS, ELECTRONICS: Not manufactured by Heat-Line, are warranted only to the extent of original manufacturer's warranty.

LABOUR, COSTS, ETC.: Heat-Line shall in **NO EVENT** be responsible or liable for the cost of field labour or other charges incurred by any customer in removing and/or reaffixing any Heat-Line product, part or component thereof.

THIS WARRANTY WILL NOT APPLY:

- defects or malfunctions resulting from failure to properly install, operate or maintain the unit in accordance with printed instructions provided,
- failures resulting from abuse, accident or negligence;

- to normal maintenance services and
- to parts not used in accordance with applicable local codes, ordinance and good trade practices;
- if the unit is moved from its original installation location or
- if the unit is used for purposes other than for what it was designed and manufactured,
- to the integral ground fault device and related electronics.

PRODUCT IMPROVEMENTS: Heat-Line reserves the right to change or improve its products or any component thereof without being obligated to provide such a change or improvement for units sold and/or shipped prior to such change or improvement.

WARRANTY EXCLUSIONS: As to any Heat-Line product after the expiration of the time period of the warranty applicable thereto as set forth above. There will be no warranties including any implied warranties of merchantability or fitness for any particular purpose. No warranties or representations at any time made by any representative of Heat-Line, shall vary or expand the provisions hereof.

LIABILITY LIMITATION: In no event shall Heat-Line be able or responsible for consequential, incidental or special damages resulting from or related in any manner to any Heat-Line product or parts thereof. In the absence of suitable proof of the purchase date, the effective date of this warranty will be based upon the date of manufacture plus 90 days.

Page left blank intentionally

Heat-Line Freeze Protection Systems

1095 Green Lake Road
Algonquin Highlands, ON Canada
KOM 1J1
Tel: (705) 754-4545
(800) 584-4944
Fax: (705) 754-4567
info@heatline.com
www.heatline.com

Heat-Line and Paladin are registered trademarks of Heat-Line Corporation.

Important: All information, including illustrations, is believed to be reliable. Users, however, should independently evaluate the suitability of each product for their particular application. Heat-Line a Division of Christopher MacLean Ltd. makes no warranties as to the accuracy or completeness of the information, and disclaims any liability regarding its use. Heat-Line's only obligations are those in the Heat-Line Standard Terms and Conditions of Sale for this product, and in no case will Heat-Line be liable for any incidental, indirect, or consequential damages arising from the sale, resale, use, or misuse of the product. Specifications are subject to change without notice. In addition, Heat-Line reserves the right to make changes—without notification to Buyer—to processing or materials that do not affect compliance with any applicable specification.



Paladin Series Warranty Form

CONGRATULATIONS!

You have just purchased the most advanced external freeze-protection system available on the market, backed by the finest warranty offered in the industry. Your Paladin Series system comes with a standard 5 year limited warranty with an optional 10 year limited warranty available.

~ The warranty applies only to the original purchaser of the product and is not transferable at any time for any reason. The warranty form must be filled out and returned to Heat-Line within 6 months of invoice date or unit manufactured date plus 9 months to be eligible for the 10 year extended warranty. ~

OWNER MAILING ADDRESS

Name _____
 Address _____

 City _____
 Prov/State _____ Postal/ZIP _____
 Canada
 USA Other: _____
 Home Phone _____
 Email _____

INSTALLATION ADDRESS (if different than mailing)

Name _____
 Address _____

 City _____
 Prov/State _____ Postal/ZIP _____
 Country _____
 Work/Cell _____

PRODUCT INFORMATION

Product Cat.# _____
 Serial # _____
 Length _____

Installation Type:
 External pipe
 Internal pipe
 Tank
 Other: _____

WARRANTY INFORMATION

5 Year Limited Warranty: **INCLUDED!**

10 Year Limited Warranty: \$1.10 / foot (\$33.00 minimum)

PAYMENT DETAILS FOR 10 YEAR LIMITED WARRANTY

System Length*	System Length*	= Subtotal
1 – 30 feet = \$ 33.00 31 – 540 feet = \$ 1.10 per foot	x \$ 1.10/ft	_____
* For custom lengths involving inches, round up to the nearest foot		

Taxes and Currency

If Canadian Address: Subtotal: _____
 Provincial Tax %: _____ Tax Due: _____
 Total in CDN Currency:

If U.S. Address or Other Country:
 No Taxes Apply
 Total in US Currency:

PAYMENT METHOD

Cheque

Enclose and make out to Heat-Line for full amount

Credit Card:

Mastercard or Visa

Name on Card: _____

Card Number: _____

Expiration Date: ____ / ____ / ____

LIMITED WARRANTY

During the time periods and subject to the conditions hereinafter set forth. Heat-Line will repair or replace to the original user any portion of your Paladin Series product which proves defective in materials or workmanship of Heat-Line. Contact Heat-Line or your installer for warranty service.

At all times Heat-Line shall have and possess the sole right and option to determine whether to repair or replace defective equipment, parts or components. **Damage due to natural events or conditions beyond the control of Heat-Line are NOT COVERED BY THIS WARRANTY.**

STANDARD WARRANTY PERIOD: 60 months from date of purchase or 63 months from date of manufacture, whichever ever occurs first.

EXTENDED WARRANTY PERIOD: 120 months from date of purchase or 123 months from date of manufacture, whichever ever occurs first.

ACCESSORIES, COMPONENTS, ELECTRONICS: Not manufactured by Heat-Line, are warranted only to the extent of original manufacturer's warranty.

LABOUR, COSTS, ETC.: Heat-Line shall in **NO EVENT** be responsible or liable for the cost of field labour or other charges incurred by any customer in removing and/or reaffixing any Heat-Line product, part or component thereof.

THIS WARRANTY WILL NOT APPLY:

(a) to defects or malfunctions resulting from failure to properly install, operate or maintain the unit in accordance with printed instructions provided,

- (b) to failures resulting from abuse, accident or negligence;
- (c) to normal maintenance services and
- (d) to parts not used in accordance with applicable local codes, ordinance and good trade practices;
- (e) if the unit is moved from its original installation location or
- (f) if the unit is used for purposes other than for what it was designed and manufactured,
- (g) to the integral ground fault device and related electronics.

PRODUCT IMPROVEMENTS: Heat-Line reserves the right to change or improve its products or any component thereof without being obligated to provide such a change or improvement for units sold and/or shipped prior to such change or improvement.

WARRANTY EXCLUSIONS: As to any Heat-Line product after the expiration of the time period of the warranty applicable thereto as set forth above. There will be no warranties including any implied warranties of merchantability or fitness for any particular purpose. No warranties or representations at any time made by any representative of Heat-Line, shall vary or expand the provisions hereof.

LIABILITY LIMITATION: In no event shall Heat-Line be able or responsible for consequential, incidental or special damages resulting from or related in any manner to any Heat-Line product or parts thereof. In the absence of suitable proof of the purchase date, the effective date of this warranty will be based upon the date of manufacture plus 90 days.

PROOF OF PURCHASE

If a proof of purchase copy is submitted with this warranty application form, the warranty period will be effective as of invoice date. In the absence of suitable proof of purchase, the effective date of this warranty will be based upon the date of unit manufacture plus 3 months.

Proof of purchase (invoice) attached: Yes No

By signing below you acknowledge you have read and understand the full limited warranty document.

Signed: _____

Dated: _____

The warranty form must be filled out and returned to Heat-Line within 6 months of invoice date or unit manufactured date plus 9 months to be eligible for 10 year extended warranty.

Heat-Line is a registered trademark of Heat-Line Corporation.

Heat-Line Freeze Protection Systems

1095 Green Lake Road / Algonquin Highlands, / KOM 1J1 / info@heatline.com / www.heatline.com
ON Canada