



Heating Polyethylene Tanks with PALADIN or EXT Series

CONCEPTUAL DRAWING

Tank Sizes Vary

To accommodate various tank shapes and sizes these concepts can be modified to suit any particular application.

Contact Heat-Line with tank size and dimensions to determine length of cable and watt density required. Once cable length is determined the actual grid layout can be designed.

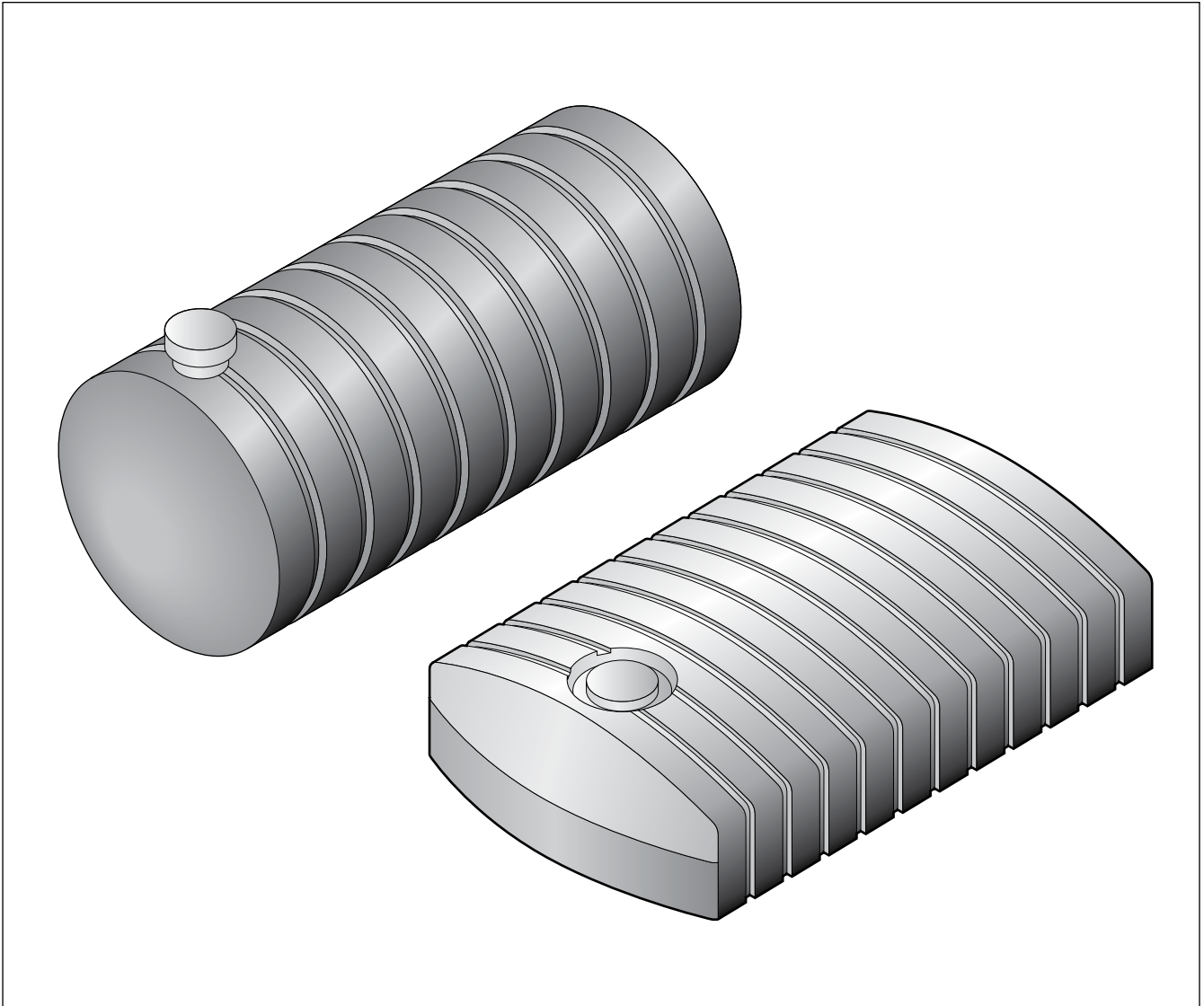

CONCEPT: Heating Polyethylene tanks with PALADIN or EXT

1

- To determine heating cable length contact Heat-Line with the following information:
 - Tank:**
Size _____ gallons
Dimensions: _____ (L) _____ (W) _____ (H)
 - Exposure ambient temperatures:**
_____ °F °C
 - Location:**
 Above grade
 Below grade
 - Insulation:**
Amount _____
Type _____
 - Voltage availability:**
 120
 208
 240

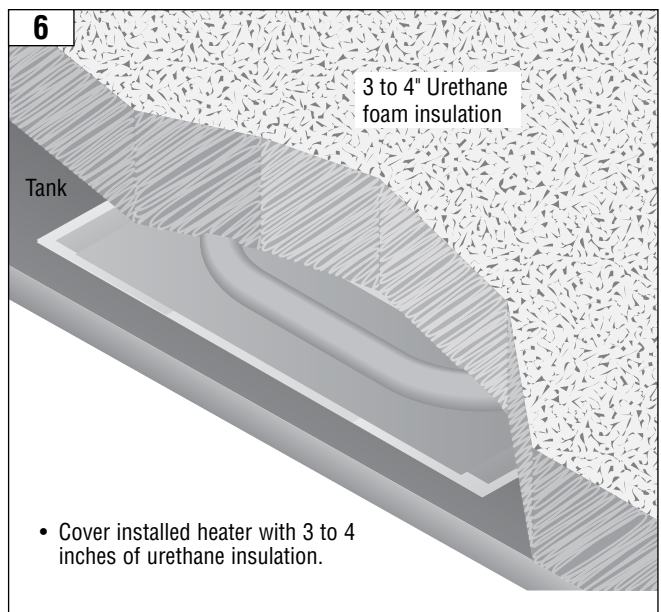
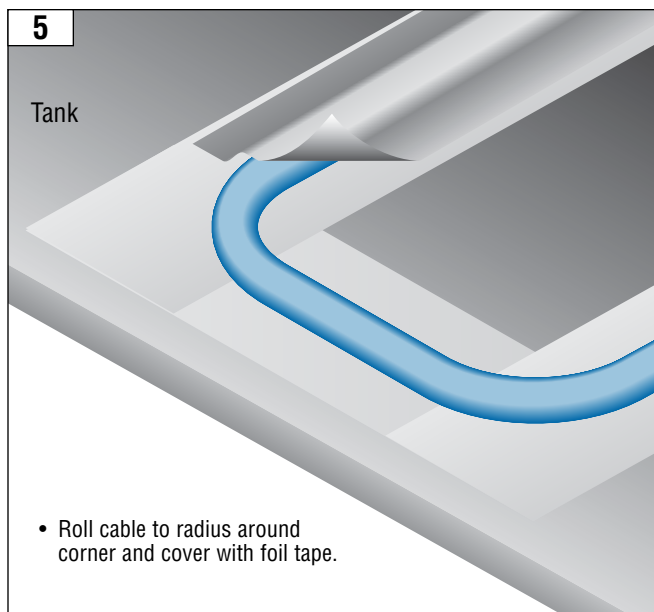
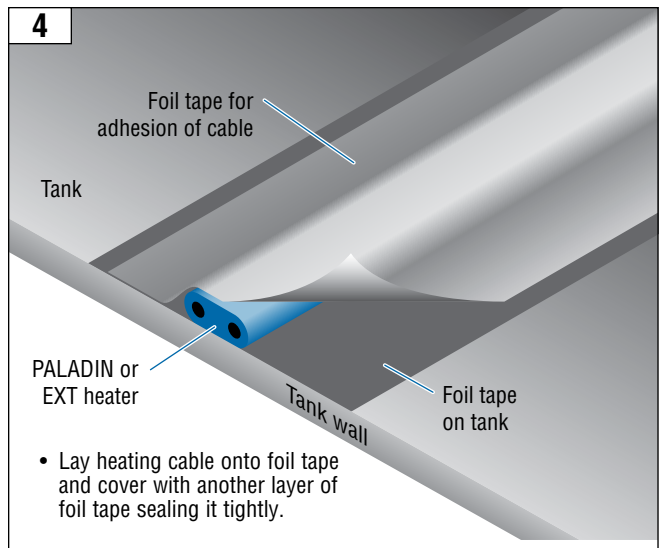
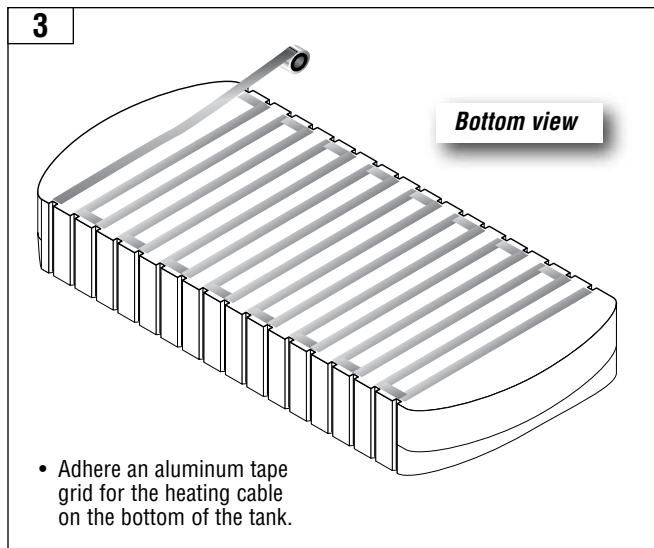
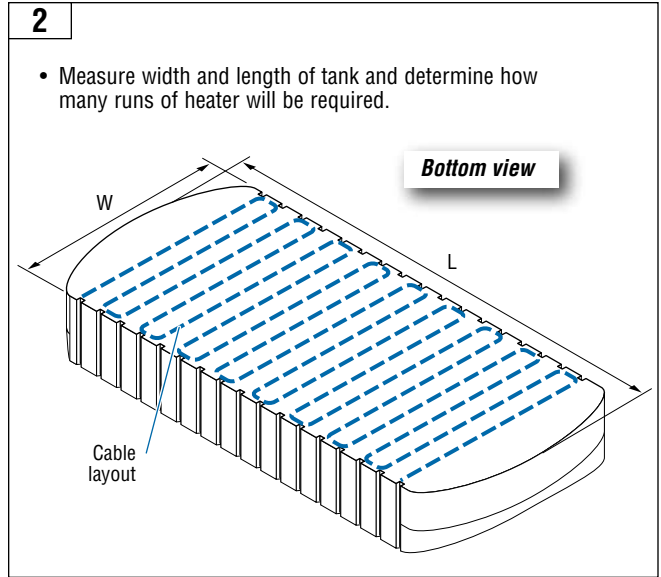

CONCEPT: Heating Polyethylene tanks with PALADIN or EXT

7

Note: Be sure foil tape is completely covering the heating cable so that the urethane foam cannot “creep” between heating cable and tank.

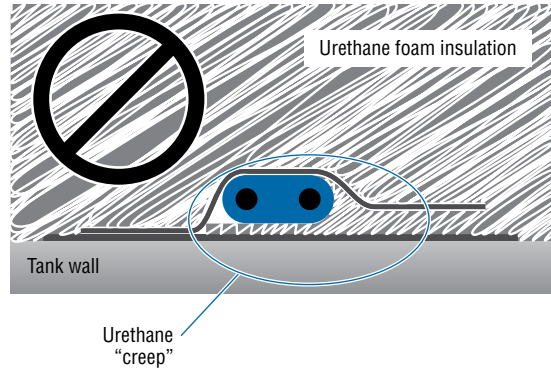
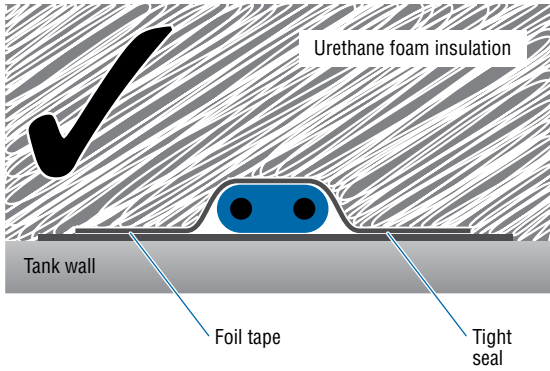

8

- Exit cold lead from tank through 1" PVC conduit

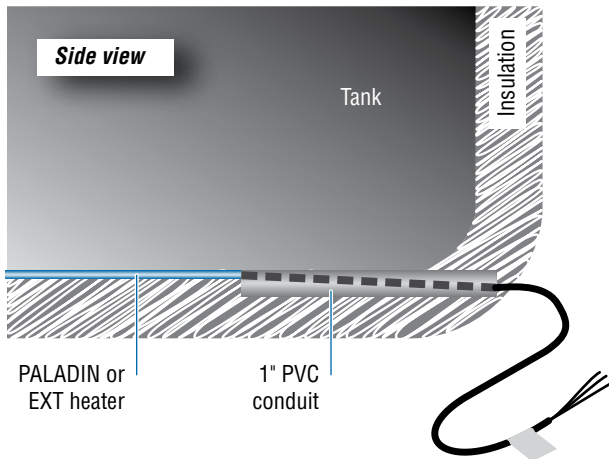

9

Optional Thermostat Installation (Recommended)

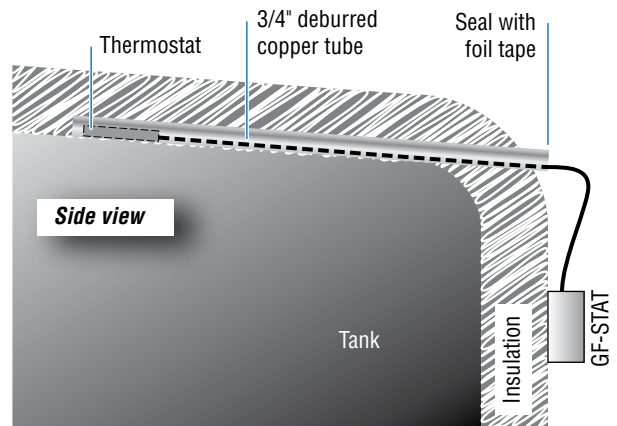

- Thermostat controls can reduce energy consumption by 60% or more.

10

- 3/4" copper tube (sleeve for sensor) mounted to top of tank with foil tape.

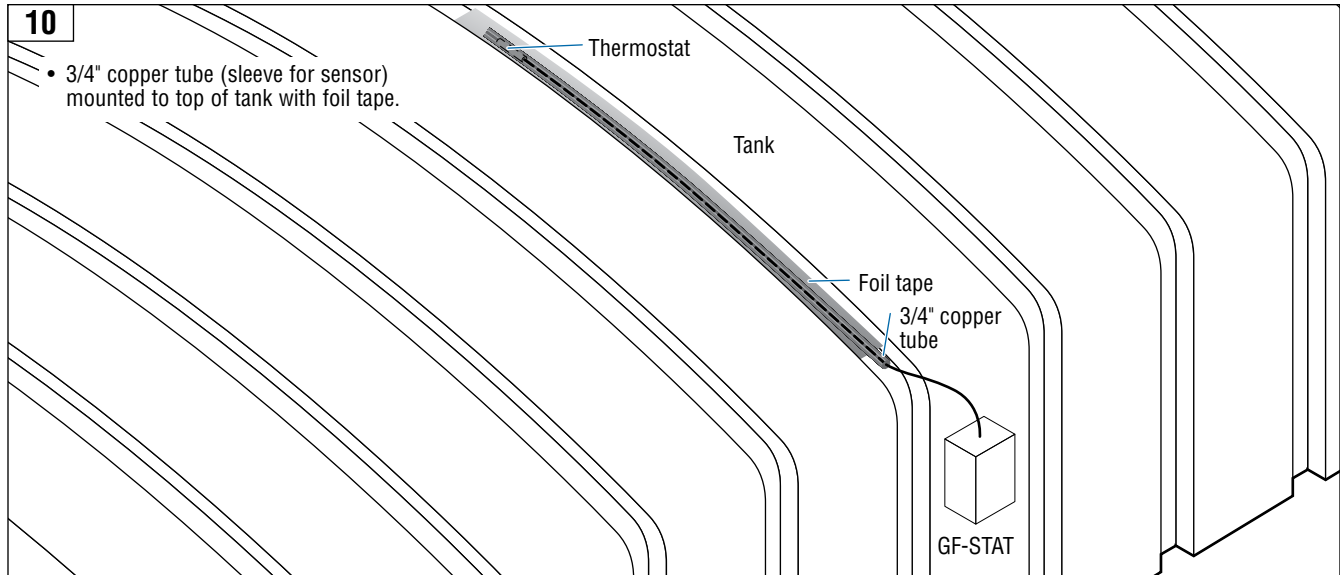

CONCEPT: Heating Polyethylene tanks with PALADIN or EXT

PALADIN is a registered trademark of Heat-Line Corporation.

Heat-Line
A division of Christopher MacLean Ltd.
1095 Green Lake Road
Carnarvon, ON Canada
K0M 1J0
Tel: (705) 754-4545
(800) 584-4944
Fax: (705) 754-4567
info@heatline.com
www.heatline.com

Important: All information, including illustrations, is believed to be reliable. Users, however, should independently evaluate the suitability of each product for their particular application. Heat-Line a Division of Christopher MacLean Ltd. makes no warranties as to the accuracy or completeness of the information, and disclaims any liability regarding its use. Heat-Line's only obligations are those in the Heat-Line Standard Terms and Conditions of Sale for this product, and in no case will Heat-Line be liable for any incidental, indirect, or consequential damages arising from the sale, resale, use, or misuse of the product. Specifications are subject to change without notice. In addition, Heat-Line reserves the right to make changes—without notification to Buyer—to processing or materials that do not affect compliance with any applicable specification.