



Cut-to-Length

Cut-to-Length Field Terminated Heating Cable

Specifications

2700, 2300, 2000 Series Self-Regulating Heating Cable

Low, Medium and High Temperature

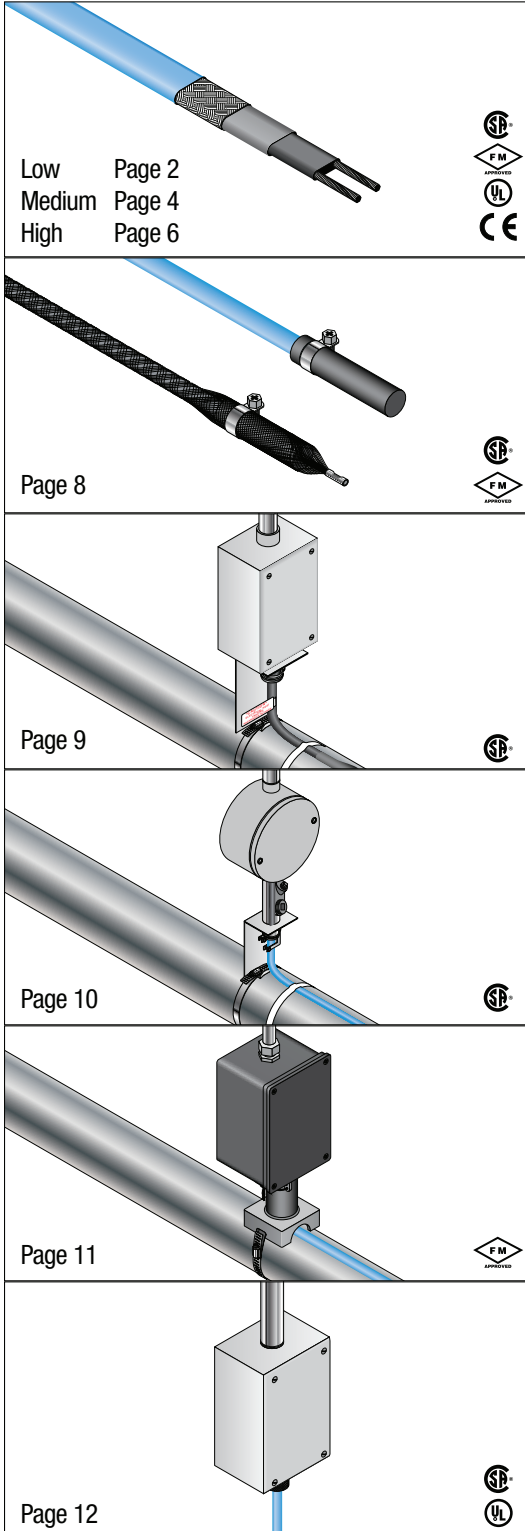

SRHC-E S End Seal Kit

For use in Ordinary and Division 2 Locations

1548-4000C

Power Connection and End Seal Kit

For use in Ordinary Locations

1548-4010C

Power Connection and End Seal Kit

For use in Ordinary and Division 2 Locations

1548-40PTP/1548-40PT J

Power Connection Kit for Pipes

For use in Ordinary and Division 2 Locations

1548-40RGP

Power Connection and End Seal Kit

For use on Roofs and in Gutters



2700 Series

Self-Regulating Heating Cable

Low Temperature

Data Sheet

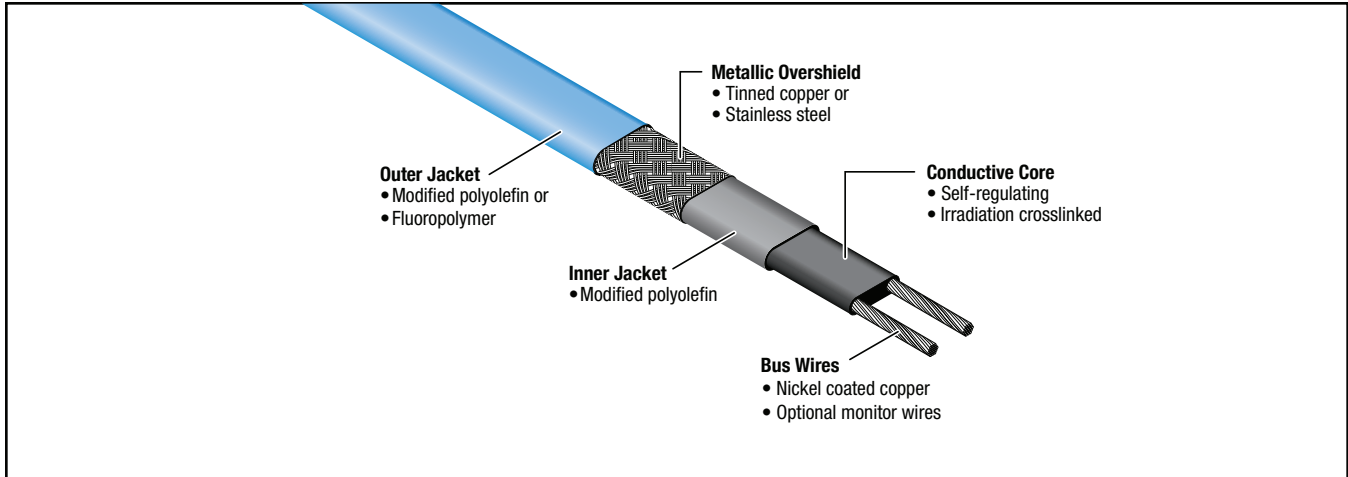

Description

Dekoron[®] Self-Regulating Heating Cables distributed by Heat-Line are designed to supply a specified amount of heat at any point along their length in direct response to local temperature variations. These cables can maintain temperatures up to 150°F (65°C) and survive intermittent exposure up to 185°F (85°C) with power applied.

The Dekoron 2700 series of self-regulating heating cables distributed by Heat-Line are designed to supply a specified amount of heat at any point along their length in direct response to local temperature variations. These cables can maintain temperatures up to 150°F (65°C) and survive intermittent exposure up to 185°F (85°C) with power applied.

Dekoron 2700 series cables can be cut to length and terminated in the field, and will not overheat or burnout when overlapped.

Applications

The industrial grade 2700 cables provide freeze protection and process temperature maintenance for fluid transport and storage systems. The bus wires, jackets and metallic braids can be configured for both ordinary (non-classified) and hazardous (classified) locations, including areas where exposure to corrosive or organic materials is possible.

Accessories

Heat-Line carries a full line of approved Dekoron accessories, including power connection kits, terminations, splices, end seals, and controls.

Performance Ratings

Output wattage	3, 5, 8, 10 w/ft @ 50°F (10°C)
Supply voltages	110 – 120 Vac or 208 – 277 Vac
Continuous maintenance temp.	150°F (65°C) max
Intermittent exposure temp.	185°F (85°C) max
T Rating*	T-5 (10 w/ft), T-6 (3, 5, 8 w/ft)
Braid resistance	
Tinned copper	0.003 Ω/ft
Stainless steel	0.125 Ω/ft

*T-Rating per the 1999 NEC, Tables 500-5(d) and verified by FM and CSA.

Approvals / Certifications



Ordinary locations
Hazardous locations

Class I, Div 1* / 2, Groups A, B, C, D
Class II, Div 1* / 2, Groups E, F, G
Class III, Div 1* and 2



Ordinary locations
Hazardous locations

Class I, Div 1* / 2, Groups B, C, D
Class II, Div 2, Groups E, F, G
Class III, Div 1* and 2



Roof and Gutter
Hot Water Maintenance



*Contact Heat-Line representative for information on Division 1 hazardous location systems.

Power Output Curves

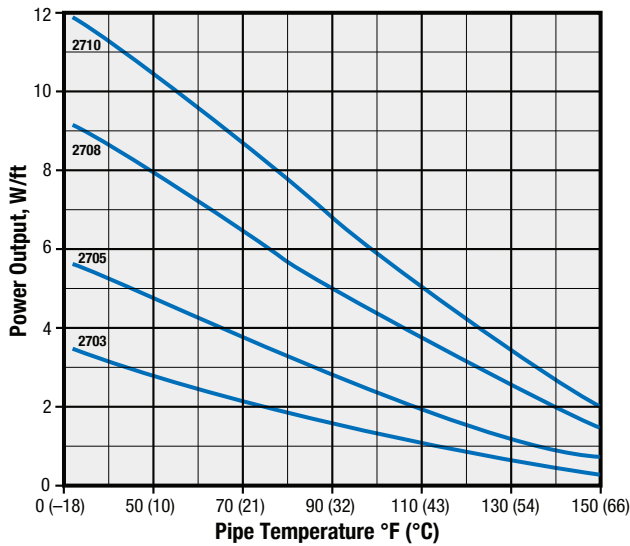

Product Ordering Information

(Example:
5 watt, 120 volt, tinned copper braid)

2705 - 1 1 C 00

- Series** _____
27 = 2700
- Output** _____
03 = 3w
05 = 5w
08 = 8w
10 = 10w
- Voltage** _____
1 = 120 Vac
2 = 240 Vac
- Class** _____
1 = Ordinary/Div. 2
3 = Ordinary/Div. 2 w/monitor wires
4 = Class I, Div. 1
- Braid Option** _____
C = Tinned copper
S = Stainless steel
T = Tinned copper w/floypolymer jacket
R = Tinned copper w/modified polymer jacket
- Reserved** _____

120 Volt Breaker Sizing vs. Max Circuit Length (ft)

		15A	20A	30A	40A
2703-1 If started at:	50°F (10°C)	300	-	-	-
	0°F (-17°C)	200	270	330	-
	-20°F (-29°C)	180	230	330	-
2705-1 If started at:	50°F (10°C)	230	270	-	-
	0°F (-17°C)	150	200	270	-
	-20°F (-29°C)	130	175	260	270
2708-1 If started at:	50°F (10°C)	150	200	210	-
	0°F (-17°C)	95	125	190	210
	-20°F (-29°C)	85	100	170	210
2710-1 If started at:	50°F (10°C)	115	150	180	-
	0°F (-17°C)	70	95	145	180
	-20°F (-29°C)	60	85	120	165

240 Volt Breaker Sizing vs. Max Circuit Length (ft)

		15A	20A	30A	40A
2703-2 If started at:	50°F (10°C)	660	-	-	-
	0°F (-17°C)	410	560	660	-
	-20°F (-29°C)	360	480	660	-
2705-2 If started at:	50°F (10°C)	460	540	-	-
	0°F (-17°C)	300	400	540	-
	-20°F (-29°C)	260	345	520	540
2708-2 If started at:	50°F (10°C)	295	390	420	-
	0°F (-17°C)	195	250	375	420
	-20°F (-29°C)	170	225	340	420
2710-2 If started at:	50°F (10°C)	230	305	360	-
	0°F (-17°C)	150	200	300	360
	-20°F (-29°C)	130	175	260	360

Note: Recommended circuit breakers to minimize the effect of transit start-up currents. Westinghouse: Types BA, EB, EHB, FB, HFB. General Electric: E100 Type TEB, E150, Types TED, THED. Square D: Types EH, FAIF. **The Canadian Electrical Code and National Electric Code requires ground fault protection of equipment for each branch circuit supplying electrical heating cables or devices.**

Power Adjustment Factor

Part No.	208 Volts	277 Volts
2703-2	0.75	1.28
2705-2	0.86	1.16
2708-2	0.91	1.10
2710-2	0.93	1.08

Heat-Line is a trademark of Heat-Line Corporation. All other trademarks are the property of their respective owners.

Heat-Line Freeze Protection Systems

1095 Green Lake Road
Algonquin Highlands, ON, Canada
KOM 1J1
Tel: 1-705-754-4545
1-800-584-4944
Fax: 1-705-754-4567
info@heatline.com
www.heatline.com

Important: All information, including illustrations, is believed to be reliable. Users, however, should independently evaluate the suitability of each product for their particular application. Heat-Line a Division of Christopher MacLean Ltd. makes no warranties as to the accuracy or completeness of the information, and disclaims any liability regarding its use. Heat-Line's only obligations are those in the Heat-Line Standard Terms and Conditions of Sale for this product, and in no case will Heat-Line be liable for any incidental, indirect, or consequential damages arising from the sale, resale, use, or misuse of the product. Specifications are subject to change without notice. Heat-Line reserves the right to make changes - without notification to Buyer - to processing or materials that do not affect compliance with any applicable specification. All heating cable products and or accessories presented in this document are distributed through Heat-Line a division of Christopher MacLean Limited in accordance with Heat Trace Products, LLC, the manufacturer.



2300 Series

Self-Regulating Heating Cable

Medium Temperature

Data Sheet

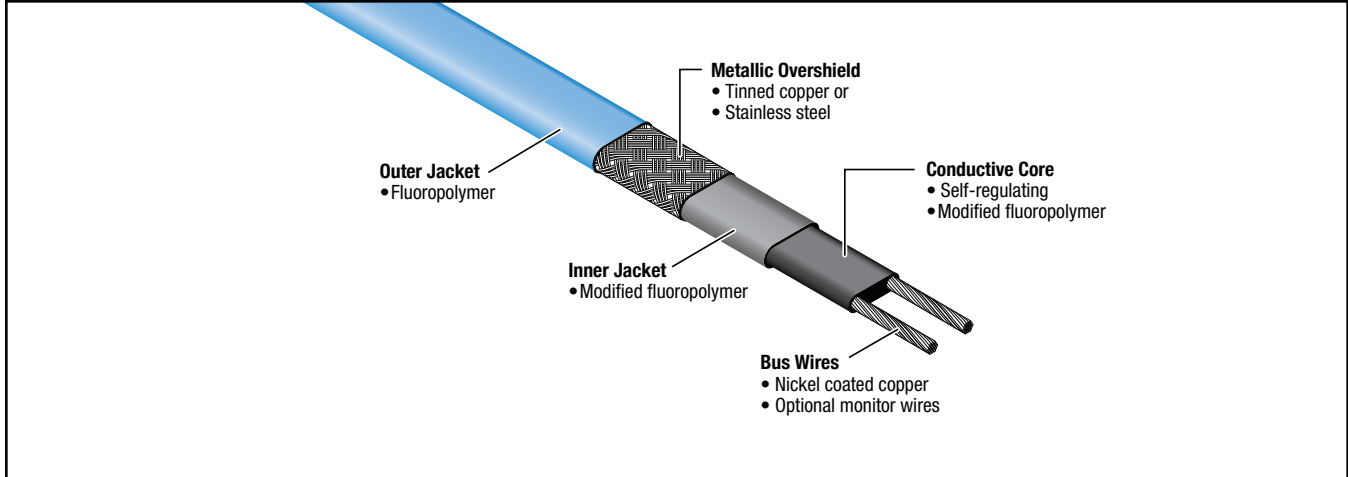

Description

The Dekoron[®] 2300 series of self-regulating heating cables distributed by Heat-Line are designed to supply a specified amount of heat at any point along their length in direct response to local temperature variations. These cables can maintain temperatures up to 250°F (120°C) and will withstand 150 psig saturated steam purging and intermittent temperature excursions to 366°F (185°C).

Dekoron 2300 series cables can be cut to length and terminated in the field, and will not overheat or burnout when overlapped.

Applications

The industrial grade 2300 cables provide freeze protection and process temperature maintenance for fluid transport and storage systems requiring high levels of heat output or exposure to elevated temperatures.

The bus wires, jackets and metallic braids can be configured for both ordinary (non-classified) locations and hazardous (classified), including areas where exposure to corrosive or organic materials is possible.

Accessories

Heat-Line carries a full line of approved Dekoron accessories, including power connection kits, terminations, splices, end seals, and controls.

Performance Ratings

Output wattage	5, 10, 15 w/ft @ 50°F (10°C)
Supply voltages	110 – 120 Vac or 208 – 277 Vac
Continuous maintenance temp.	250°F (120°C) max
Intermittent exposure temp.	366°F (185°C) max
T Rating*	T-3
Braid resistance	
Tinned copper	0.003 Ω/ft
Stainless steel	0.125 Ω/ft

*T-Rating per the 1999 NEC, Tables 500-5(d) and verified by FM and CSA.

Approvals / Certifications



Ordinary locations
STD-130-03-G,-W,-S

Hazardous locations
Class I, Div 1* / 2, Groups A, B, C, D
Class II, Div 1* / 2, Groups E, F, G
Class III, Div 1* and 2



Ordinary locations
Hazardous locations
Class I, Div 1* / 2, Groups B, C, D
Class II, Div 2, Groups F, G
Class III, Div 2



*Contact Heat-Line representative for information on Division 1 hazardous location systems.

Power Output Curves

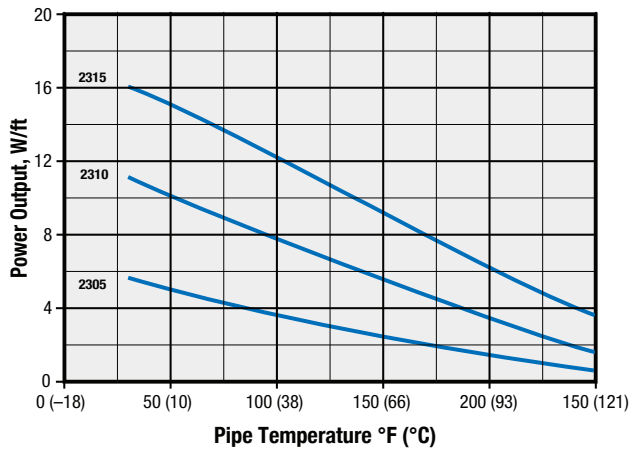

Product Ordering Information

(Example:
5 watt, 120 volt, tinned copper braid)

2305 - 1 1 C 00

Series _____
23 = 2300

Output _____
05 = 5w
10 = 10w
15 = 15w

Voltage _____
1 = 120 Vac
2 = 240 Vac

Class _____
1 = Ordinary/Div. 2
3 = Ordinary/Div. 2 w/monitor wires
4 = Class I, Div. 1

Braid Option _____
C = Tinned copper
S = Stainless steel
T = Tinned copper w/floouopolymer jacket

Reserved _____

120 Volt Breaker Sizing vs. Max Circuit Length (ft)

		15A	20A	30A
2305-1 If started at:	50°F (10°C)	150	200	240
	0°F (-17°C)	135	180	220
	-40°F (-40°C)	130	170	210
2310-1 If started at:	50°F (10°C)	90	120	180
	0°F (-17°C)	85	110	165
	-20°F (-29°C)	80	105	160
2315-1 If started at:	50°F (10°C)	70	90	130
	0°F (-17°C)	65	85	125
	-20°F (-29°C)	60	80	120

240 Volt Breaker Sizing vs. Max Circuit Length (ft)

		15A	20A	30A
2305-2 If started at:	50°F (10°C)	250	330	480
	0°F (-17°C)	230	305	440
	-20°F (-29°C)	220	295	420
2310-2 If started at:	50°F (10°C)	140	190	280
	0°F (-17°C)	130	175	260
	-20°F (-29°C)	125	170	250
2315-2 If started at:	50°F (10°C)	100	135	200
	0°F (-17°C)	95	125	185
	-20°F (-29°C)	90	120	180

Note: Recommended circuit breakers to minimize the effect of transit start-up currents. Westinghouse: Types BA, EB, EHB, FB, HFB. **General Electric** : E100 Type TEB, E150, Types TED, THED. **Square D** : Types EH, FAIF. The National Electric Code requires ground fault protection of equipment for each branch circuit supplying electrical heating cables or devices. **The Canadian Electrical Code and National Electric Code requires ground fault protection of equipment for each branch circuit supplying electrical heating cables or devices.**

Power Adjustment Factor

Part No.	208 Volts	277 Volts
2305-2	0.78	1.25
2310-2	0.86	1.16
2315-2	0.92	1.09

Heat-Line is a trademark of Heat-Line Corporation. All other trademarks are the property of their respective owners.

Heat-Line Freeze Protection Systems

1095 Green Lake Road
Algonquin Highlands, ON, Canada
KOM 1J1
Tel: 1-705-754-4545
1-800-584-4944
Fax: 1-705-754-4567
info@heatline.com
www.heatline.com

Important: All information, including illustrations, is believed to be reliable. Users, however, should independently evaluate the suitability of each product for their particular application. Heat-Line a Division of Christopher MacLean Ltd. makes no warranties as to the accuracy or completeness of the information, and disclaims any liability regarding its use. Heat-Line's only obligations are those in the Heat-Line Standard Terms and Conditions of Sale for this product, and in no case will Heat-Line be liable for any incidental, indirect, or consequential damages arising from the sale, resale, use, or misuse of the product. Specifications are subject to change without notice. Heat-Line reserves the right to make changes - without notification to Buyer - to processing or materials that do not affect compliance with any applicable specification. All heating cable products and or accessories presented in this document are distributed through Heat-Line a division of Christopher MacLean Limited in accordance with Heat Trace Products, LLC, the manufacturer.



2000 Series Self-Regulating Heating Cable High Temperature

Data Sheet

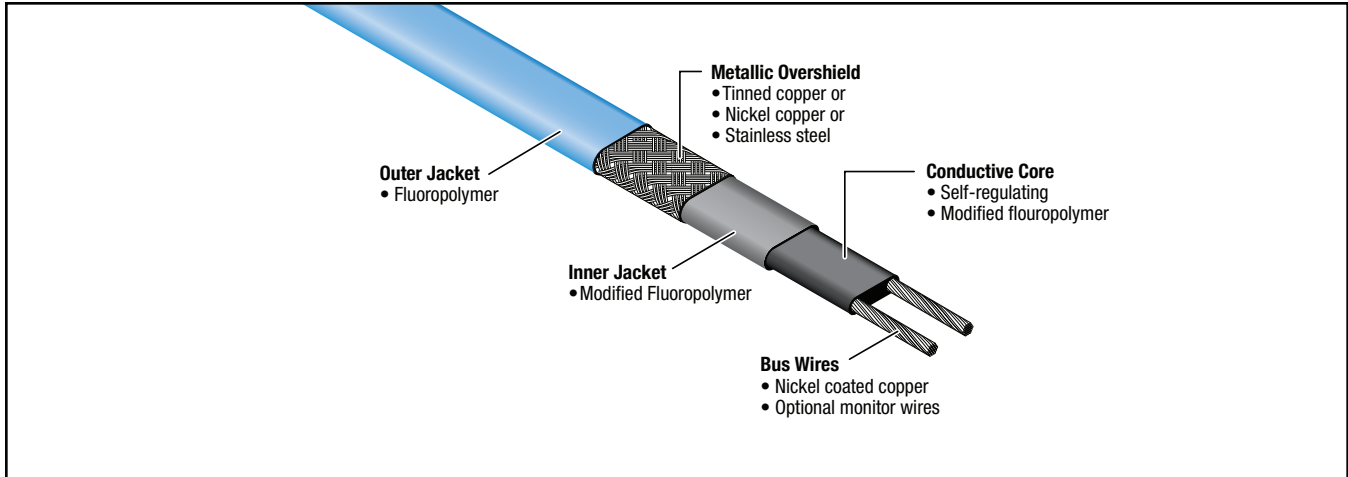

Description

The 2000 series of self-regulating heating cables are designed to supply a specified amount of heat at any point along their length in direct response to local temperature variations.

These cables can maintain temperatures up to 375°F (190°C) and will withstand 190 psig saturated steam purging and intermittent temperature excursions to 450°F (232°C) with power applied.

2000 series cables can be cut to length and terminated in the field, and will not overheat or burnout when overlapped..

Applications

The industrial grade 2000 cables provide freeze protection and process temperature maintenance for fluid transport and storage systems requiring very high levels of heat output or exposure to elevated temperatures.

The bus wires, jackets and metallic braids can be configured for both ordinary (non-classified) locations and hazardous (classified), including areas where exposure to corrosive or organic materials is possible.

Accessories

Heat-Line carries a full line of approved Dekoron accessories, including power connection kits, terminations, splices, end seals, and controls.

Performance Ratings

Output wattage	5 through 30w/ft @ 50°F (other wattages also available)
Supply voltages	110 – 120 Vac or 208 – 277 Vac
Continuous maintenance temp.	375°F (190°C) max
Intermittent exposure temp.	450°F (232°C) max
T Rating*	T-2C
Braid resistance	
Tinned copper	0.003 Ω/ft
Stainless steel	0.125 Ω/ft

*T-Rating per the 1999 NEC, Tables 500-5(d) and verified by FM and CSA.

Approvals / Certifications



Ordinary locations

3(A,B,C), 5(A,B)

Hazardous locations

Class I, Div 1* / 2, Groups B, C, D
Class I, Div 2, Groups B, C, D
Class II, Div 2, Groups F, G



Ordinary locations

Hazardous locations

Class I, Div 1*, Groups B, C, D
Class I, Div 2, Groups A, B, C, D
Class II/III, Div 1*, Groups E, F, G
Class II/III, Div 2, Groups F, G
Class I, Zone 1*, Group IIB + H2,
Class I, Zone 2, Group IIC



SEMCO - (CE mark):

*Contact Heat-Line representative for information on Division 1 hazardous location systems.

Power Output Curves

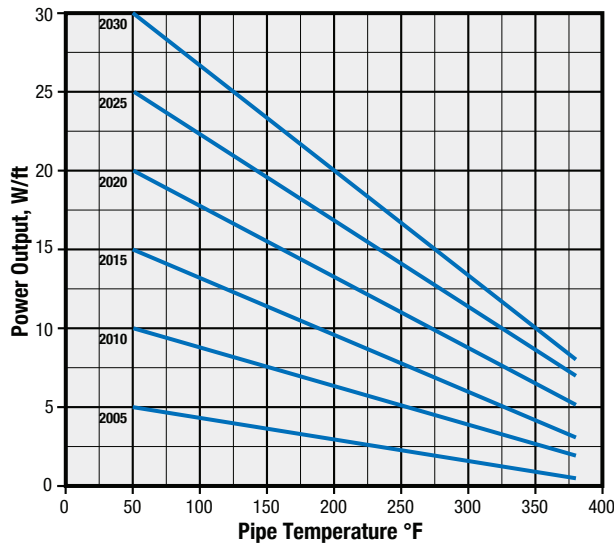

Product Ordering Information

(Example:
5 watt, 120 volt, tinned copper braid)

2005 - 1 1 C 00

Series _____
20 = 2000

Output _____
05 = 5w 20 = 20w
10 = 10w 25 = 25w
15 = 15w 30 = 30w

Voltage _____
1 = 120 Vac
2 = 240 Vac

Class _____
1 = Ordinary/Div. 2
3 = Ordinary/Div. 2 w/monitor wires
4 = Class I, Div. 1

Braid Option _____
C = Tinned copper
S = Stainless steel
K = Nickel copper
T = Tinned copper w/fouropolymer jacket
F = Stainless steel w/fouropolymer jacket
M = Nickel copper w/fouropolymer jacket

Reserved _____

Power Adjustment Factor

Part No.	208 Volts	277 Volts
2010-2	0.88	1.14
2020-2	0.94	1.08
2030-2	0.99	1.01

120 Volt Breaker Sizing vs. Max Circuit Length (ft)

		15A	20A	30A
2005-1 If started at:	50°F (10°C)	180	240	335
	0°F (-18°C)	165	220	330
	-50°F (-45°C)	150	200	300
2010-1 If started at:	50°F (10°C)	120	160	180
	0°F (-18°C)	105	140	180
	-50°F (-45°C)	90	120	180
2015-1 If started at:	50°F (10°C)	80	105	135
	0°F (-18°C)	70	90	135
	-50°F (-45°C)	60	80	120
2020-1 If started at:	50°F (10°C)	60	90	120
	0°F (-18°C)	55	70	110
	-50°F (-45°C)	50	65	100
2025-1 If started at:	50°F (10°C)	45	60	85
	0°F (-18°C)	40	50	80
	-50°F (-45°C)	40	50	80
2030-1 If started at:	50°F (10°C)	40	50	70
	0°F (-18°C)	35	45	70
	-50°F (-45°C)	35	45	70

240 Volt Breaker Sizing vs. Max Circuit Length (ft)

		15A	20A	30A
2005-2 If started at:	50°F (10°C)	360	480	540
	0°F (-18°C)	325	430	540
	-50°F (-45°C)	290	385	540
2010-2 If started at:	50°F (10°C)	240	320	360
	0°F (-18°C)	230	305	360
	-50°F (-45°C)	225	300	360
2015-2 If started at:	50°F (10°C)	160	210	270
	0°F (-18°C)	140	185	270
	-50°F (-45°C)	120	160	240
2020-2 If started at:	50°F (10°C)	115	150	230
	0°F (-18°C)	110	145	220
	-50°F (-45°C)	105	140	210
2025-2 If started at:	50°F (10°C)	90	120	170
	0°F (-18°C)	80	100	160
	-50°F (-45°C)	80	100	160
2030-2 If started at:	50°F (10°C)	80	100	140
	0°F (-18°C)	70	90	140
	-50°F (-45°C)	70	90	140

Note: Recommended circuit breakers to minimize the effect of transit start-up currents. Westinghouse: Types BA, EB, EHB, FB, HFB. General Electric: E100 Type TEB, E150, Types TED, THED. Square D: Types EH, FAIF. **The Canadian Electrical Code and National Electric Code requires ground fault protection of equipment for each branch circuit supplying electrical heating cables or devices.**

Heat-Line is a trademark of Heat-Line Corporation. All other trademarks are the property of their respective owners.

Heat-Line Freeze Protection Systems

1095 Green Lake Road
 Algonquin Highlands, ON, Canada
 KOM 1J1
 Tel: 1-705-754-4545
 1-800-584-4944
 Fax: 1-705-754-4567
 info@heatline.com
 www.heatline.com

Important: All information, including illustrations, is believed to be reliable. Users, however, should independently evaluate the suitability of each product for their particular application. Heat-Line a Division of Christopher MacLean Ltd. makes no warranties as to the accuracy or completeness of the information, and disclaims any liability regarding its use. Heat-Line's only obligations are those in the Heat-Line Standard Terms and Conditions of Sale for this product, and in no case will Heat-Line be liable for any incidental, indirect, or consequential damages arising from the sale, resale, use, or misuse of the product. Specifications are subject to change without notice. Heat-Line reserves the right to make changes - without notification to Buyer - to processing or materials that do not affect compliance with any applicable specification. All heating cable products and or accessories presented in this document are distributed through Heat-Line a division of Christopher MacLean Limited in accordance with Heat Trace Products, LLC, the manufacturer.



SRHC-ES End Seal Kit

For use with Dekoron 2700 and 2300 Families of Heating Cables in Ordinary and Division 2 Locations

Specifications

Kit Description

The Dekoron[®] SRHC-ES end seal kit distributed by Heat-Line is used for making the end seal termination for Dekoron 2700 and 2300 Family of Heating Cables.

Tools Required

- Flat-head screwdriver
- Diagonal cutting pliers
- Utility knife or razor blade
- Phillips screwdriver
- Barrel crimp tool

Approvals



Non-Hazardous Locations

Hazardous Locations

- Class I, Div. 2, Group A, B, C, D
- Class II, Div. 2, Group E,F
- Class III, Div. 2



Non-Hazardous Locations

Hazardous Locations

- Class I, Div. 2, Group B, C, D
- Class II, Div. 2, Group F,G
- Class III

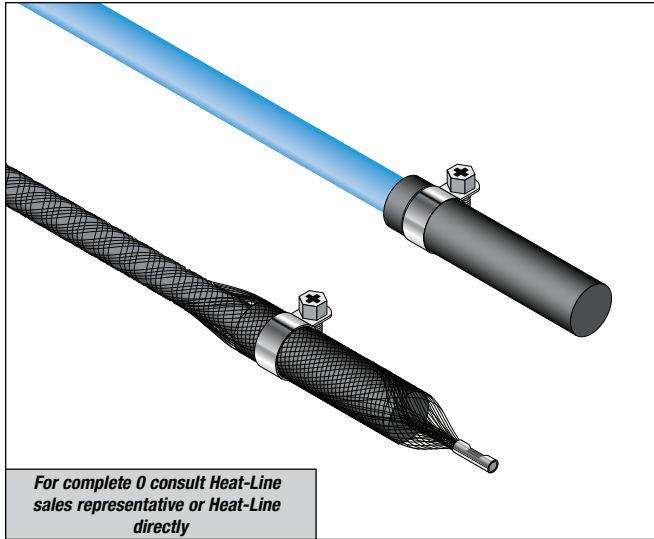

For complete O consult Heat-Line sales representative or Heat-Line directly

Kit Parts

Item	Qty	Description
A	1	End Cap
B	1	RTV Sealant
C	1	Clamp
D	1	Barrel Crimp

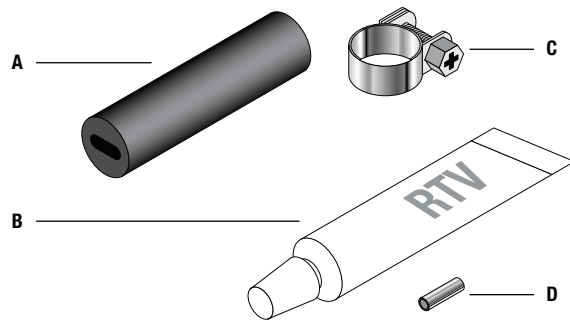

WARNING:

- The Canadian Electrical Code and National Electric Code requires ground fault protection of equipment for each branch circuit supplying electrical heating cables or devices.
- If the heating cable has a stainless steel ground braid, the following caution applies: The metal covering shall not be used as the bonding-to-ground means. Alternative means of protection shall be provided per CE Code part I.
- For cable installed in outdoor or wet indoor locations, use a suitable weather proofing cover (such as aluminum jacketing) to protect the thermal insulation.
- After thermal insulation is complete the insulation resistance of the entire branch circuit should not be less than 10M ohms.
- Ground metal structures used for support or on which the cable is installed in accordance with CE Code part 1, Section 10.
- Install cable at -22°F (-30°C) or above.
- Do not install heater closer than 1/2 inch to any exposed combustible surface, unless the cable has a metal shield or sheath and is provided with a positive temperature control which will limit the surface temperature to a value not exceeding 162°F (72°C).
- Minimum bending radius for heating cable is 1/4 inch.



1548-4000C Power Connection Kit

For Use With Dekoron 2700 Family
of Heating Cables

Specifications

Kit Description

The Dekoron® 1548-4000C electrical connection kit distributed by Heat-Line is used for making electrical and end-seal connections for the Dekoron 2700 Family of heating cables.

Tools Required

- Flat-head screwdriver
- Pliers
- Diagonal cutting pliers
- Utility knife or razor blade
- Wire stripper cutter
- Measuring tape
- Needle-nose pliers
- Crimp tool

Additional Materials Required (but not provided)

- Weather tight junction box (Damp or Wet Locations)
- Standard junction box (Ordinary location)
- Pipe strap (for pipe sizes other than 2 in. to 6 in. O.D.)
- Additional fiberglass tape or nylon cable ties

Approvals



Non-Hazardous Locations

Heating Cable Types 3A, 3B, 3C

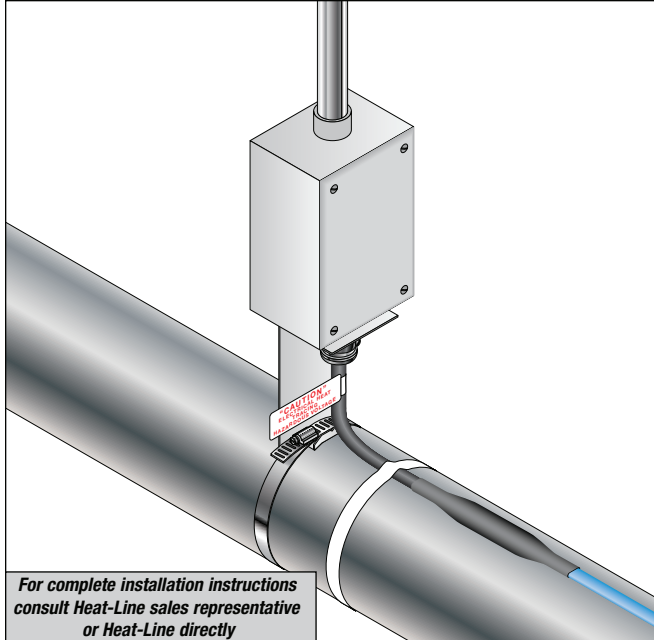

For complete installation instructions
consult Heat-Line sales representative
or Heat-Line directly

Kit Parts

Item	Qty	Description
A	1	Connector Body
	1	Gland Washer
	1	Gland Nut
B	1	Grommet
C	1	Locknut
D	1	Cold Lead Cable – 14/3, 18"
E	5	Insulated Butt Connectors – 14-16 AWG
F	1	Insulated Butt Connector – 10-12 AWG
G	1	Caution Label
H	1	Standoff Bracket
I	1	Roll of Fiberglass Tape
J	1	Heat Shrink Tube (1/2" x 6")
K	1	Pipe strap (for 2" to 6" O.D. Pipes)
L	1	End Seal Boot

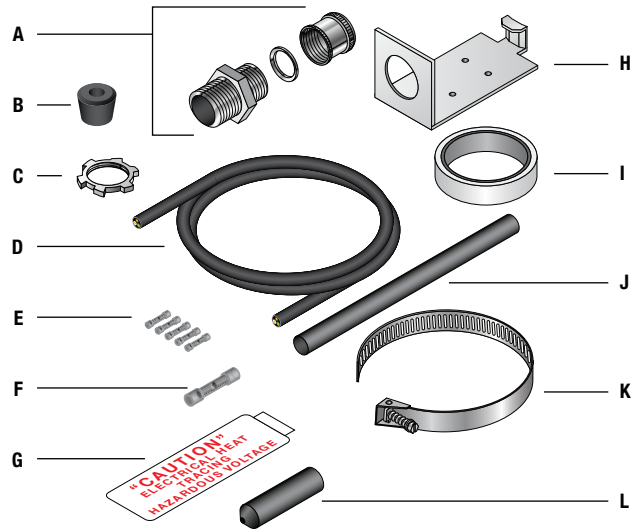

WARNING:

- The Canadian Electrical Code and National Electric Code requires ground fault protection of equipment for each branch circuit supplying electrical heating cables or devices.
- If the heating cable has a stainless steel ground braid, the following caution applies: The metal covering shall not be used as the bonding-to-ground means. Alternative means of protection shall be provided per CE Code part I.

- For cable installed in outdoor or wet indoor locations, use a suitable weather proofing cover (such as aluminum jacketing) to protect the thermal insulation.
- After thermal insulation is complete the insulation resistance of the entire branch circuit should not be less than 10M ohms.
- Ground metal structures used for support or on which the cable is installed in accordance with CE Code part 1, Section 10.

- Install at -22°F (-30°C) or above.
- Do not install heater closer than 1/2 inch to any exposed combustible surface unless the cable has a metal shield or sheath and is provided with a positive temperature control which will limit the surface temperature to a value not exceeding 162°F (72°C).
- Minimum bending radius for heating cable is 1/4 inch.



1548-4010C Electrical Connection Kit

For Use With Dekoron 2700 and 2300 Family of Heating Cables

Specifications

Kit Description

The Dekoron® 1548-4010C electrical connection and end seal kit distributed by Heat-Line contains components needed to make one power input connection and one end termination in Ordinary or Division 2 locations; or one power input connection in Division 1 locations; or one end termination in Division 1 locations. Splices and power input splices can be made by using 2 kits.

Tools Required

- Flat-head screwdriver
- Wire cutters
- Diagonal cutting pliers
- Needle-nose pliers
- Utility knife or razor blade
- Crimp tool
- Phillips screwdriver

Additional Materials Required (but not provided)

- Weather Tight Junction Box (3/4 in. NPT Hubs)*
- Sealing Fitting (Division 1)*
- Pipe Strap (for pipe sizes other than 2 in. to 6 in. O.D.)
- Additional Fiberglass Tape

* The hazardous location designation of the complete cable set is governed by the lowest hazardous location rating of the sealing fitting and outlet box.

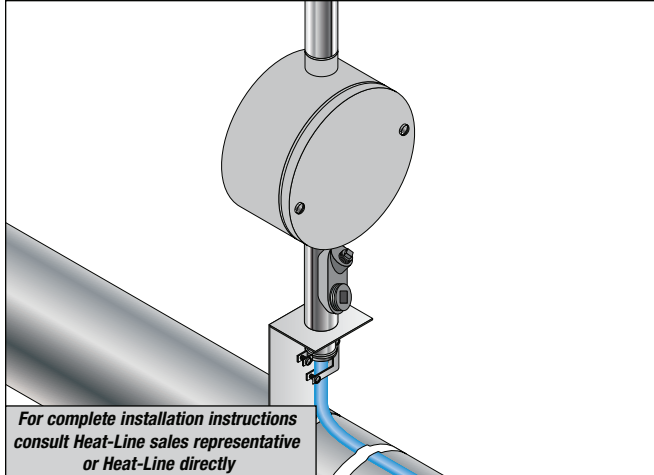

Approvals



Non-Hazardous Locations / Hazardous Locations

- Class I, Div 1*/2, Groups A, B, C, D
- Class II, Div 1*/2, Groups E, F, G
- Class III, Div 1* and 2

*Contact Heat-Line representative for information on Division 1 hazardous location systems.

Power Connection Kit Parts

Item	Qty	Description
A	1	Connector Cap
	2	Connector Gland Washers
	1	Connector Body
B	1	Grommet
C	1	Locknut
D	1	Termination Block
E	1	Termination Boot
F	1	Silicone Sealant
G	1	Strain Relief Rip
H	1	Standoff Bracket
I	1	Roll of Fiberglass Tape
J	1	Ring Tongue Terminal
K	1	Pipe Strap (for 2" to 6" O.D. Pipes)
L	1	End Seal Kit

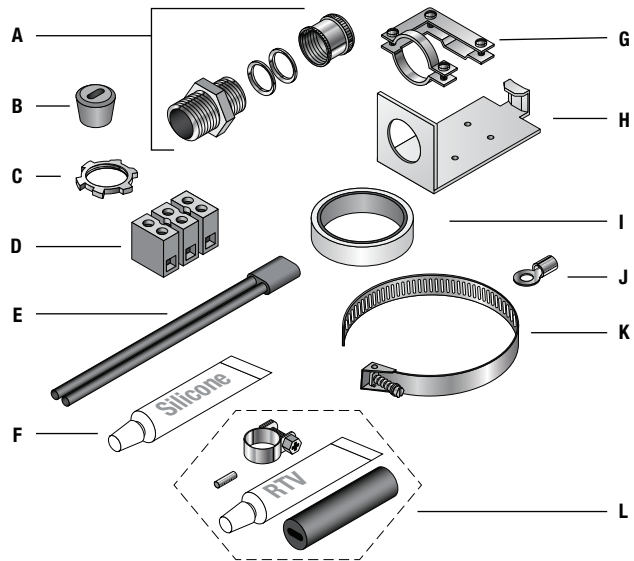

WARNING:

- The Canadian Electrical Code and National Electric Code requires ground fault protection of equipment for each branch circuit supplying electrical heating cables or devices.
- If the heating cable has a stainless steel ground braid, the following caution applies: The metal covering shall not be used as the bonding-to-ground means. Alternative means of protection shall be provided per CE Code part I.

- For cable installed in outdoor or wet indoor locations, use a suitable weather proofing cover (such as aluminum jacketing) to protect the thermal insulation.
- After installation of thermal insulation is complete, the insulation resistance of the system should not be less than 10 Mohms when measured at 500 Vdc between each circuit and ground with set de-energize and all circuit neutrals isolated from ground.
- Ground metal structures used for support or on which the cable is installed in accordance with CE Code part 1, Section 10.

- Install at -22°F (-30°C) or above.
- Do not install heater closer than 1/2 inch to any exposed combustible surface unless the cable has a metal shield or sheath and is provided with a positive temperature control which will limit the surface temperature to a value not exceeding 162°F (72°C).
- Minimum bending radius for heating cable is 1/4 inch.



1548-40PTP/1548-40PTJ Power Connection Kit for Pipes

For use with Dekoron 2700 and 2300 Families of Heating Cables. 1548-81HTJ/81HTP for use with 2000 Series Heating Cables.

Specifications

Kit Description

The Dekoron 1548-40PTP/1548-40PTJ electrical connection kit distributed by Heat-Line is designed for use in ordinary and Division 2 locations. The kit provides excellent resistance to ultraviolet rays from sun, as well as inorganic chemicals and most corrosives. The 1548-40PTP/1548-40PTJ electrical connection kit does not include an end seal termination.

Contact Heat-Line directly for recommendations on end seal termination kits suitable for your application.

Tools Required

- Ruler or tape measure
- Utility knife
- Needle-nose pliers
- Flat blade screw driver
- Diagonal cutters
- Heat gun or mini torch

Additional Materials Required (but not provided)

- Appropriately sized pipe clamp
- Conduit grounding clamp (for heater without overbraid)

Approvals



Non-Hazardous and Div. 2 Approved Locations

Class I, Div. 2 Groups A, B, C, D
Class II/III, Div. 2 Groups F,G
Class 1, Zone 2 Groups IIC

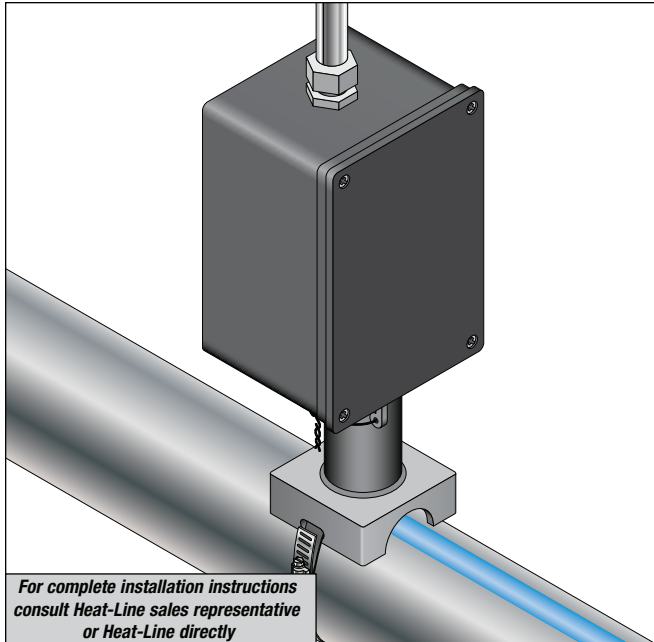

Kit Contents

Item	Qty	Description
A	1	Lock Ring
B	1	Sealing Gasket
C	1	Top
D	1	Sealing Grommet (Small Hole for Heating Cable with Ground Braid Only and No Outer Jacket)
E	1	Sealing Grommet (Large Hole for Heating Cable with Ground Braid and Outer Jacket)
F	2	Heat Shrink Tubes – Black (1/8" x 5-1/2")
G	1	Stainless Steel Wire
H	1	Base
I	1	Adaptor (For Installation on Pipe Smaller Than 1")
J	1	Heat Shrink Tube – Green/yellow (1/4" x 5-1/2")
K	1	Heat Shrink Tube – Clear (1/2" x 1-1/2")
L	1	NEMA 4X junction box (4-1/2" H x 3" W x 2 1/2" D) (Included with 1548-40 PTJ Kit)

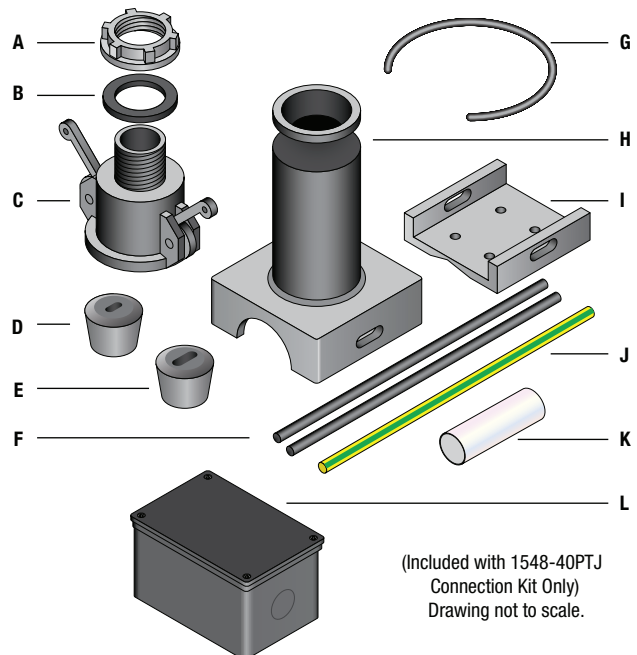

⚠ WARNING:

- The Canadian Electrical Code and National Electric Code requires ground fault protection of equipment for each branch circuit supplying electrical heating cables or devices.
- If the heating cable has a stainless steel ground braid, the following caution applies: The metal covering shall not be used as the bonding-to-ground means. Alternative means of protection shall be provided per CE Code part I.

- Ground metal structures used for support on which the cable is installed in accordance with CE Code part I, Section 10.
- For cables installed in outdoor or wet indoor locations, use a suitable weatherproofing cover (such as aluminum jacketing) to protect the thermal insulation.
- After installation of thermal insulation is complete, the insulation resistance of the system should not be less than 10 Mohms when measured at 500 Vdc between each circuit and ground with set de-energized and all circuit neutrals isolated from ground.

- Install at –22°F (–30°C) or above.
- Do not install heater closer than 1/2 inch to any exposed combustible surface unless the cable has a metal shield or sheath and is provided with a positive temperature control which will limit the surface temperature to a value not exceeding 162°F (72°C).
- Minimum bending radius for heating cable is 1/4 inch.



1548-40RGP

Power Connection and End Seal Kit

For use on Roofs and in Gutters

Specifications

Kit Description

The Dekoron[®] 1548-40RGP power connection kit for roof and gutters distributed by Heat-Line includes materials for one power connection and one end seal termination.

For use with Dekoron 2705-1RG (-2RG) as CSA type 2E for roof and gutter de-icing.

For use with Dekoron 2705-11T (-21T) as UL Listed snow melting and de-icing equipment.

Tools Required

- Ruler or tape measure
- Utility knife
- Needle-nose pliers
- Flat blade screw driver
- Diagonal cutters
- Heat gun or propane torch

Additional Materials Required (but not provided)

- Appropriate junction box and lock nut

Approvals



De-Icing and Snow Melting Equipment
when used with associated kits and installed per manufacturer's instructions.



Certified Roof De-Icing
when used with associated kits and installed per manufacturer's instructions.

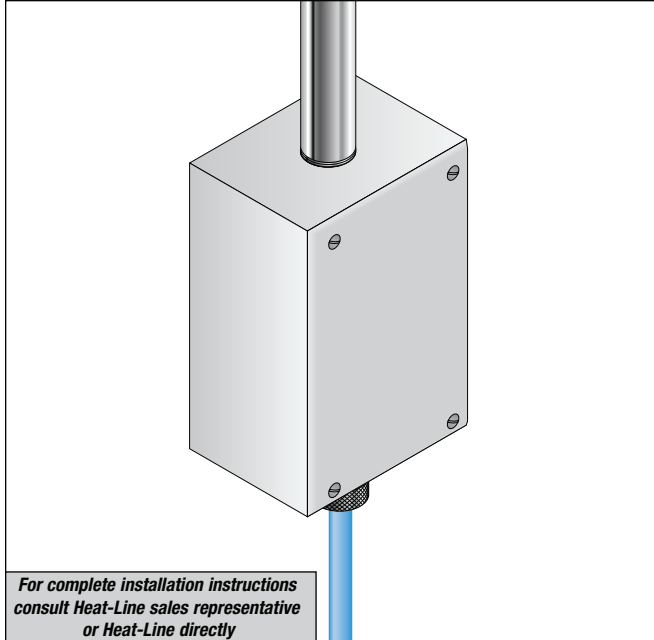

For complete installation instructions consult Heat-Line sales representative or Heat-Line directly

Power Connection Kit Parts

Item	Qty	Description
A	1	Sealing Fitting
B	1	Grounding Screw
C	1	Grommet
D	1	Heat Shrink Tube – Black (1/2" x 1-1/2")
E	2	Heat Shrink Tubes – Black (1/8" x 5-1/2")
F	1	Heat Shrink Tube – Green (1/4" x 5-1/2")
G	1	Wire Nut 18-12 AWG – Red
H	2	Wire Nuts 20-12 AWG – Yellow

End Seal Kit Parts

J	1	Heat Shrink Tube – Black (3/4" x 4")
K	1	Heat Shrink Tube – Black (1/2" x 1-1/2")

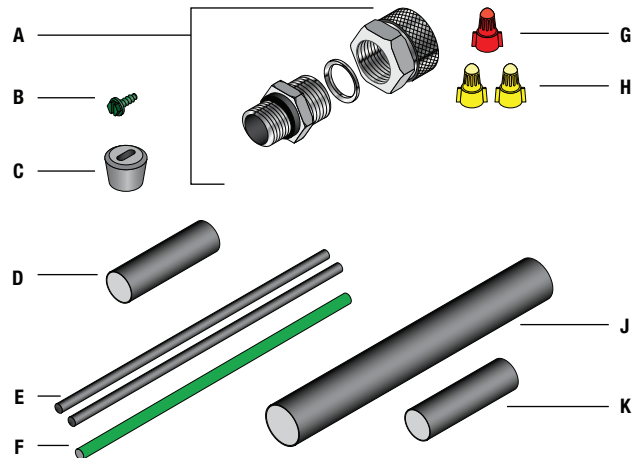

⚠ WARNING:

- The Canadian Electrical Code and National Electric Code requires ground fault protection of equipment for each branch circuit supplying electrical heating cables or devices.
- The contents of the component kit must be installed correctly to ensure proper operation and to prevent shock and fire. Read these important warnings and carefully follow all the installation instructions.
- Overheating heat-shrink tubes will produce fumes that may cause irritation. Use adequate ventilation and avoid charring or burning.
- To minimize the danger of fire from sustained electrical arcing if the heating cable is damaged or improperly installed, use a ground fault protection device. Arcing may not be stopped by conventional circuit breakers.
- Component approvals and performance are based on the use of specified parts only. Do not substitute parts or use vinyl electrical tape.
- The black heating-cable core is conductive and can short. It must be properly insulated and kept dry.
- Damaged bus wires can overheat or short. Do not break bus wire strands when preparing the cable for installation.
- Bus wires will short if they contact each other. Keep bus wires separated.
- Heat-damaged components can short. Use a heat gun or torch with a soft yellow low-heat flame; not a blue focused flame. Keep the flame moving to avoid overheating, blistering, or charring the heat-shrink tubes. Avoid heating the other components. Replace any damaged parts.