

# Cut-to-Length Heating Cable

*Industrial and Commercial Self-Regulating Heating Cable.*

Cut-to-Length Heating Cables are top quality commercial, industrial self-regulating heating cables and power connection kits for ordinary and hazardous locations, roof and gutter de-icing.



SCAN ME

See more product information, photos, technical documents, and more



## General Heater Specifications

<b>Buss Wire</b>	14-16 AWG copper or nicked copper
<b>Conductive core</b>	Self-regulating/conductive polymer
<b>Inner jacket</b>	Polyolefin
<b>Metallic overshield/Braid</b>	Copper, tinned copper or stainless steel
<b>Outer jacket</b>	Modified Polyolefin or Fluoropolymer
<b>Watts per foot/meter</b>	3, 5, 8, 10/foot or 10-33/meter
<b>Voltage</b>	110 - 120 Vac or 208 - 277 Vac
<b>Approvals</b>	CSA, FM, UL
<b>Environmental use(s)</b>	<ul style="list-style-type: none"> <li>• Ordinary areas</li> <li>• Div. 2 hazardous locations</li> <li>• Corrosive environments</li> <li>• Roof and gutter</li> </ul>
<b>Reel length</b>	Up to 1000 feet
<b>Water resistant jacket</b>	Yes
<b>Flame retardant jacket</b>	Yes
<b>Can be overlapped</b>	Yes
<b>Applications</b>	<ul style="list-style-type: none"> <li>• Freeze protection of pipes</li> <li>• Fire protection system piping</li> <li>• Chilled water and plumbing pipes</li> <li>• Sump pump discharge pipes</li> <li>• Exposed P-traps</li> <li>• Cooling towers</li> <li>• Vessel freeze protection</li> <li>• Fluid flow and viscosity maintenance</li> <li>• Process temperature maintenance</li> <li>• Roof and gutter</li> </ul>

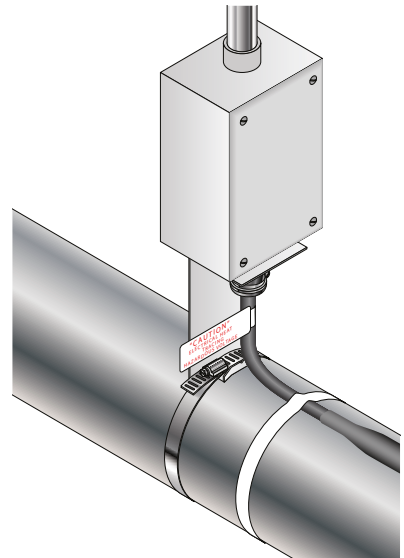
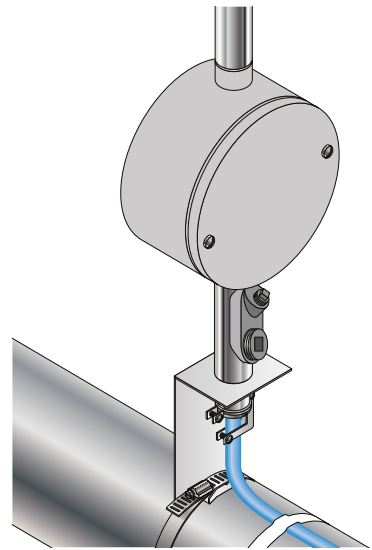

## Self-Regulating Heating Cable

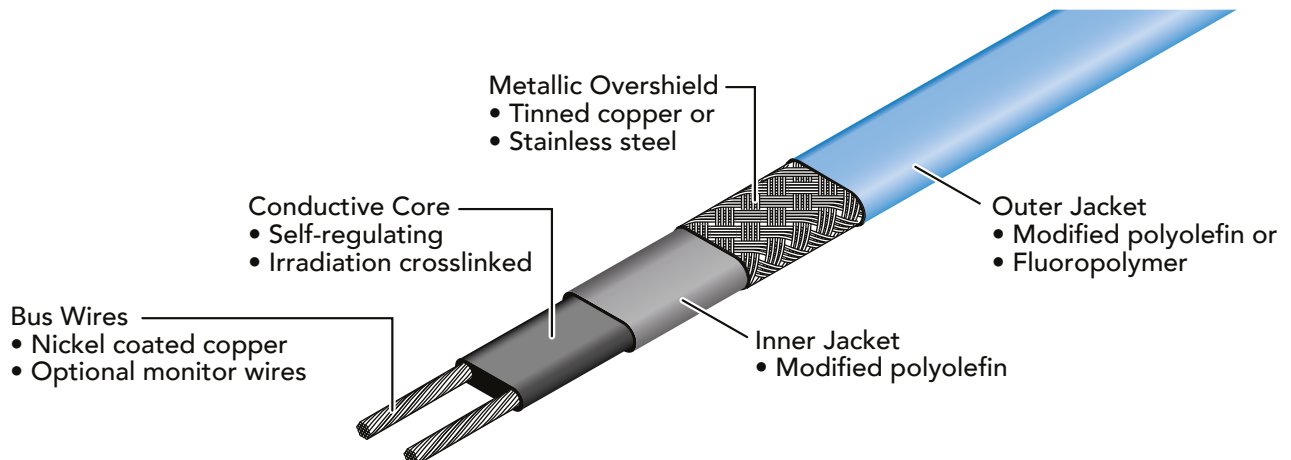



## Heating Cable Options

Heat-Line provides excellent Cut-to-Length heat cables in a large or small order requirements at very competitive prices. These cables can maintain temperatures up to 150°F (65°C) and survive intermittent exposure up to 185°F (85°C) with power applied. They are designed for all types of heat tracing including pipe tracing, roof and gutter de-icing, vessel tracing and many more. All heating cables are North American made by the top manufacturers providing you a reliable solution.

## Cost Savings

Many manufacturers specify their specific cables in various building plans, and Heat-Line's vast resource of products will almost always meet the building specification, providing equivalent performance with huge cost savings to the contractor. Heat-Line provides excellent Cut-to-Length heating cables in large or small order requirements at very competitive prices.

## Industrial, Commercial

Heat-Line is a sole source, high volume provider of multiple types of industrial and commercial self-regulating heating cables, components and controls. Heat-Line carries major inventories with a full understanding of the products and can provide extremely competitive pricing.

## Meets or Exceeds Most Building Specs

Heating cables are available in 120, 208, 240 and 277 volts, and wattages ranging from 3 to 10 watts per foot or 10 to 33 watts per meter. All heating cables meet or exceed most building specifications and carry regulatory approvals from CSA, FM and/or UL for ordinary and hazardous locations. Control options include: ambient and line sensing thermostats, snow melt sensors, ground fault protected thermostats and more.

## Common Applications

Heat-Line Cut-to-Length freeze protection heating cables are ideal for keeping metallic and non-metallic pipes from freezing. These heat cables provide safe, reliable heat tracing for freeze protection of pipes, valves, tanks and similar applications. In commercial construction applications, these heaters can be used on a variety of applications such as; cooling towers, chilled water and plumbing pipes, sump discharge pipes, fire protection system piping and exposed P-traps. For industrial applications, their usage can include; water treatment facilities, vessel freeze protection and safety lines. Cut-to-Length heating cables are also ideal for process temperature maintenance, pipe freeze protection, fluid flow and viscosity maintenance. Medium and high temperature industrial and commercial grade self-regulating heating cables are also available.

## Self-Regulating Technology

All Heat-Line Cut-to-Length heating cables offer the unique and advanced performance of self-regulating heating cable technology. These heaters can effectively increase heat and energy output to sections along its length which are cold and simultaneously reduce heat and energy output to sections which are warm. Even in applications where pipes are intended to be dry for short or extended periods of time, the heating cable will never over-heat or melt the pipe. These high quality heaters give you the peace of mind of reliable freeze protection without the risk. It has become an essential product for electricians, engineers and building officials overseeing commercial, industrial and municipal projects to provide safe and reliable pipe freeze protection.

# Cut-to-Length Heating Cable Ordering Chart

## 2700 Series Heating Cable Example Shown

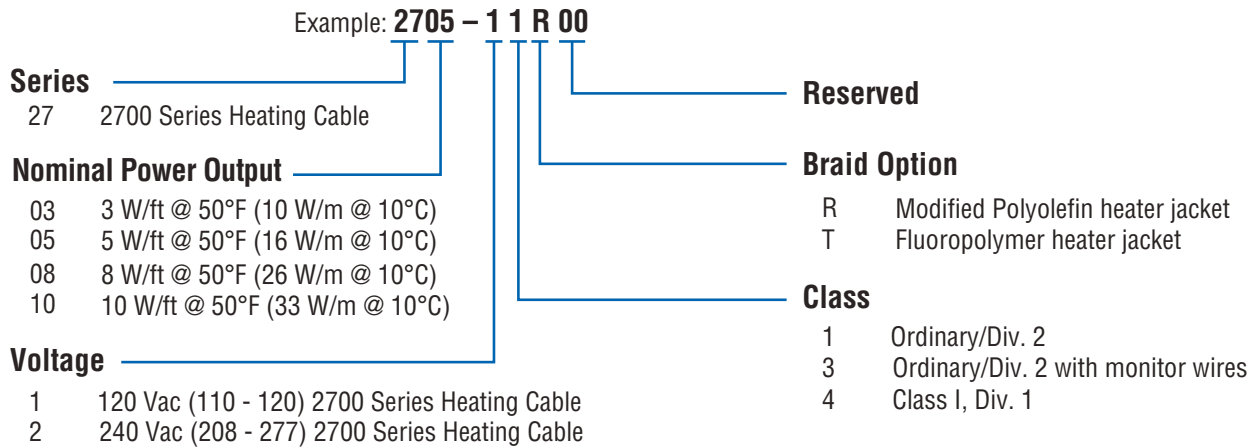

## Electrical Connection Kits | Product Codes

- 1548-40000** Power and end seal connection kit, FM hazardous and non-hazardous
- 1548-4000C** Power and end seal connection kit, CSA non-hazardous
- 1548-4010C** Power and end seal connection kit, CSA hazardous and non-hazardous
- 1548-40PTJ** Power connection kit, FM hazardous and non-hazardous
- 1548-40RGP** Power and end seal kit, roof and gutter, CSA, UL
- SRHC-ES** End seal kit, CSA/FM hazardous and non-hazardous

*For specific approval information on the above connection kits contact Heat-Line*

Note: Other heating cables and electrical connection kits available by special request.

## Cut-to-Length Heating Cable | Accessories

<b>GFA-STAT</b>	120/240V hard wire thermostat GFEP (CS)	<b>GIT-1</b>	Gutter ice sensor (requires controller, PD-PRO or GF-PRO)
<b>1660-13A11</b>	Line sensing thermostat, 25-325F, NEMA 4X Ordinary	<b>SNOW-OWL</b>	Aerial snow sensor (requires controller, PD-PRO or GF-PRO)
<b>1660-13A12</b>	Line sensing thermostat, 25-325F, FM Class 1 Div 1	<b>LCD-8</b>	Configurable snow switch controller
<b>1660-18911</b>	Ambient sensing thermostat, Ordinary Location	<b>PD-PRO</b>	Snow/ice controller
<b>MA-10</b>	120/240V GFCI/ELCI (CS)	<b>GF-PRO</b>	Snow/ice controller with GFEP
<b>DS-8C-CONTROLLER</b>	Rain/snow sensor controller c/w remote 10' sensor	<b>PLD-RDK</b>	Downspout hanger kit
<b>DS-8C-EX-50</b>	Rain/snow sensorextension 50' kit for DS-8C	<b>PLD-RC</b>	Roof clips (package of 10)
		<b>1528-01017</b>	2700 Series fiberglass tape, 130C rated, 60 yards or 180ft per roll ½" wide
		<b>PLD-EC</b>	EDGE-CUTTER to suit (refer to page 51)